



CITY OF BARTOW  
**CODE ENFORCEMENT - SPECIAL MAGISTRATE MEETING**  
TUESDAY, APRIL 28, 2026 AT 9:00 AM  
OR AS SOON THEREAFTER AS POSSIBLE  
450 NORTH WILSON AVE., BARTOW, FL 33830

**AGENDA**

1. CALL TO ORDER
2. PLEDGE OF ALLEGIANCE TO THE FLAG
3. APPROVAL OF MINUTES
  - a. March 31, 2026
4. EXPLANATION OF PROCEDURE AND SWEARING IN
5. AGENDA MODIFICATION
6. CONSENT AGENDA - All matters listed under this section are considered to be routine and action will be accomplished by one motion without a separate discussion of each item. If discussion is desired by the Special Magistrate, that item(s) will be removed from the Consent Agenda and considered separately.
  - A. AFFIDAVIT OF NON-COMPLIANCE/FINE CERTIFICATIONS
    - a. **CASE NO. 26-0117-PH**  
**RESPONDENT:** LANCE FAGAN  
**LOCATION:** 470 SHADY LANE ST.  
BARTOW, FL 33830  
**VIOLATION(S):** MPMS 302.1 SANITATION
7. OLD BUSINESS
8. NEW VIOLATIONS
  - a. **CASE NO. 26-0111-DT**  
**RESPONDENT:** FRANCES RADFORD, YVONNE M. WASHINGTON, MARION MOTELY, TAMARA L. BOSTIC, TIMOTHY BENNETT, REGINALD WASHINGTON, WANDA B. JOHNSON, FREDERICK WASHINGTON, SHARLEASE W. GRANDBERRY, ANDREA WASHINGTON, WARREN WASHINGTON, AND AARON WASHINGTON  
**VIOLATION(S):** 1. MPMS 304.7 ROOFS AND DRAINAGE
9. REPEAT VIOLATIONS

10. DEMOLITION REQUESTS

11. REDUCTION REQUESTS

12. ADJOURNMENT

(References to “MPMS” are to the Minimum Property Maintenance Standards of the City of Bartow as adopted by the Bartow Property Improvement Regulations Ordinance of 2012 (“BPIRO”), § 18-16, Code of Ord. of the City of Bartow, Fla. References to the “FBC” are to the Florida Building Code as modified by BPIRO, §§ 18-1, 18-2, Code of Ord. of the City of Bartow, Fla. References to “ULDC” are to the Unified Land Development Code of the City of Bartow, Fla.)

Please be advised that if you desire to appeal from any decisions made as a result of the above hearing or meeting, you will need a record of the proceedings and in some cases a verbatim record is required.

You must make your own arrangements to produce this record. (Florida Statute 286.0105). If you are a person with a disability who needs any accommodation in order to participate in this proceeding, you are entitled, at no cost to you, to the provision of certain assistance. Please contact the City Clerk’s Office at 450 N. Wilson Avenue, P.O. Box 1069, Bartow, Florida 33831-1069 or phone (863) 534-0100 within 2 working days of your receipt of this meeting notification; if you are hearing or voice impaired, call 1-800-955-8771. Posted at City Hall, Bartow Public Library, and the City’s website [www.cityofbartow.net](http://www.cityofbartow.net) on April 21, 2026.

CITY OF BARTOW  
**CODE ENFORCEMENT - SPECIAL MAGISTRATE HEARING**  
TUESDAY, MARCH 31, 2026 AT 9:00 A.M. (EST)  
OR AS SOON THEREAFTER AS POSSIBLE  
CITY HALL COMMISSION CHAMBERS,  
450 NORTH WILSON AVENUE, BARTOW, FL 33830

MINUTES

The Special Magistrate Hearing for the City of Bartow Code Enforcement convened on March 31, 2026, at 9:00 a.m. in the Commission Chambers located at City Hall, 450 N. Wilson Avenue, Bartow, FL 33830. Notice of this meeting was posted at City Hall, Bartow Public Library, and on the City's website, [www.cityofbartow.net](http://www.cityofbartow.net), on March 24, 2026.

**1. CALL TO ORDER**

Special Magistrate Mawhinney called the hearing to order at 9:01 a.m.

**2. PLEDGE OF ALLEGIANCE TO THE FLAG**

Special Magistrate Mawhinney led the Pledge of Allegiance to the Flag.

**3. APPROVAL OF THE MINUTES – February 24, 2026**

Special Magistrate Mawhinney approved the minutes from February 24, 2026, as presented.

**4. EXPLANATION OF PROCEDURE AND SWEARING-IN**

Special Magistrate Mawhinney explained that he would call each case as it appears on the agenda. He stated that the Code Enforcement Investigator responsible for the case would present testimony, and then anyone in the audience who is here on behalf of the property owner(s) or anyone wishing to speak specifically to that case would be allowed to offer testimony. He asked that everyone would be courteous and respectful of each other.

Special Magistrate Mawhinney swore in those wishing to testify.

**5. AGENDA MODIFICATION – None**

**6. CONSENT AGENDA**

All matters listed under this section are considered to be routine and action will be accomplished by one motion without a separate discussion of each item. If discussion is desired by the Special Magistrate, that item(s) will be removed from the Consent Agenda and considered separately.

**A. AFFIDAVITS OF NON-COMPLIANCE / FINE CERTIFICATIONS – None**

**7. OLD BUSINESS – None**

**8. NEW VIOLATIONS –**

**a. CASE NO. 25-0124 – DT**

**RESPONDENT: ANTHONY PETERSON & AMP PROPERTY INVESTMENT SOLUTIONS, LLC**

**LOCATION: 2060 MACON ST**

**VIOLATION(S):**

**1. IPMS 302.7 ACCESSORY STRUCTURE**

Code Compliance Inspector Tait personally took the photographs associated with this case, and they accurately depicted what she saw. During routine patrol, she found the above violation to exist. On February 17, 2026, a Notice of Violation was posted on the subject property, and City Hall and mailed via certified and first-class mail. The property was reinspected on March 30, 2026, and the violation was not corrected. The City has incurred investigative costs of \$128.78. She requests the property owner be given thirty (30) days to come into compliance, or be fined \$100 per day, plus associated city costs.

The Respondent(s), Anthony Peterson and AMP Property Investment Solutions, LLC, was duly served with notice of the subject hearing and did not attend this hearing (arrived at 9:08 a.m.).

**SPECIAL MAGISTRATE MAWHINNEY** accepted the photographs into evidence. He found the violation to exist. He gave the property owner thirty (30) days to bring the property into compliance, or a fine of \$100 per day would be imposed. The City's current administrative cost of \$128.78 for prosecuting the case was imposed and is payable within thirty (30) days.

**b. CASE NO. 25-0125 – DT**

**RESPONDENT: ANTHONY PETERSON & AMP PROPERTY INVESTMENT SOLUTIONS, LLC**

**LOCATION: 2060 MACON ST**

**VIOLATION(S):**

**1.MPMS 38-26 OVERGROWTH OF WEEDS, ACCUMULATION OF DEBRIS, VEGETATION, AND OTHER MATTER CONSTITUTING HEALTH HAZARD DECLARED NUISANCE**

Code Compliance Inspector Tait personally took the photographs associated with this case, and they accurately depicted what she saw. During routine patrol, she found the above violation to exist. On February 17, 2026, a Notice of Violation was posted on the subject property, and City Hall and mailed via certified and first-class mail. The property was reinspected on March 30, 2026, and the violation was not corrected. The City has incurred investigative costs of \$128.78. She requests the property owner be given thirty (30) days to come into compliance, or be fined \$100 per day, plus associated city costs.

Mr. Peterson reported that he had spoken with the adjoining property owner regarding a fence that was located approximately two feet onto his own property. He stated that after returning from a period of residence in Atlanta, he learned from the adjoining owner that his fence had been removed, his mailbox was destroyed in the process, and a gate had

been thrown into his yard. Mr. Peterson noted that the code investigator had contacted him and that he was cooperating to bring his property into compliance.

The Respondent(s), Anthony Peterson and AMP Property Investment Solutions, LLC, were duly served with notice of the subject hearing and did attend this hearing (9:08 a.m.).

**SPECIAL MAGISTRATE MAWHINNEY** accepted the photographs into evidence. He found the violation to exist. He gave the property owner thirty (30) days to bring the property into compliance, or a fine of \$100 per day would be imposed. The City's current administrative cost of \$128.78 for prosecuting the case was imposed and is payable within thirty (30) days.

c. **CASE NO. 26-0108 – DT**

**RESPONDENT: ANTHONY PETERSON & AMP PROPERTY INVESTMENT SOLUTIONS, LLC**

**LOCATION: 2060 MACON ST**

**VIOLATION(S):**

**1.MPMS 304-13 EXTERIOR STRUCTURE**

Code Compliance Inspector Tait personally took the photographs associated with this case, and they accurately depicted what she saw. During routine patrol, she found the above violation to exist. On March 19, 2026, a Notice of Hearing was posted on the subject property, and City Hall and mailed via certified and first-class mail. The property was reinspected on March 30, 2026, and the violation was not corrected. The City has incurred the investigative costs of \$92.52. She requests the property owner be given thirty (30) days to come into compliance, or be fined \$100 per day, plus associated city costs.

The Respondent(s), Anthony Peterson and AMP Property Investment Solutions, LLC, were duly served with notice of the subject hearing and did attend this hearing.

Special Magistrate Mawhinney inquired why three separate cases had been opened rather than one case with multiple violations.

Inspector Tait explained that the current departmental system does not support consolidating multiple violations under a single case number.

Mr. Peterson stated that he was unaware the window was open, believing instead that it had been damaged. He noted previous break-in attempts at the property and suspected the open window may have resulted from another attempted break-in. Mr. Peterson assured us that all issues at the property would be resolved within 30 days.

Magistrate Mawhinney advised Mr. Peterson to maintain communication with Code Enforcement once the property has been brought into compliance.

**SPECIAL MAGISTRATE MAWHINNEY** accepted the photographs into evidence. He found the violation to exist. He gave the property owner thirty (30) days to bring the property into compliance, or a fine of \$100 per day would be imposed. The City's current administrative cost of \$92.52 for prosecuting the case was imposed and is payable within

thirty (30) days.

**d. CASE NO. 25-0186-LH**  
**RESPONDENT: RANDALL DOUGLAS NEWMAN**  
**LOCATION: 680 GARDEN ST.**  
**VIOLATION(S):**  
**1.MPMS 302.87 MOTOR VEHICLE**

Code Compliance Inspector Hodge personally took the photographs associated with this case, and they accurately depicted what she saw. During routine patrol, she found the above violation to exist. On November 18, 2025, a Notice of Violation was posted on the subject property, and City Hall and mailed via certified and first-class mail giving the property owner thirty (30) days to come into compliance. Prior to reinspection date of December 20, 2025, the respondent phoned and requested an extension, a new compliance date was set for February 1, 2026. Upon reinspection on February 1, 2026, violations were not corrected. Spoke with respondent on February 5, 2026, at 9:40 am, who stated she lost her cat, had been depressed and that it has been too cold. I provided an additional 30-day extension advising respondent progress would need to be made to avoid further enforcement actions. The new inspection date was set for March 7, 2026. The property was reinspected on March 9, 2026, and the violation was not corrected. The City has incurred the investigative costs of \$157.24. She requests the property owner be given thirty (30) days to come into compliance, or be fined \$150 per day, plus associated city costs.

The Respondent(s), Randall Douglas Newman, was duly served with notice of the subject hearing and did not attend this hearing. Attorney Melissa Wilson was present representing property owner Tina Barnes.

Attorney Wilson stated that Ms. Barnes currently resides at the property, while the property owner, Randall Newman, no longer lives there and has not for some time. The motor vehicles in question are registered to Mr. Newman, and Ms. Barnes is unable to have them removed since she is not the registered owner.

Attorney Wilson further explained that Ms. Barnes has been working to install fencing around the property to bring it into compliance. However, as a single mother of two and the sole income provider, her financial resources are limited. Additionally, Ms. Barnes is managing health issues that restrict the amount of physical work she can perform at one time.

Magistrate Mawhinney inquired about the expected timeframe for bringing the property into compliance.

Ms. Barnes requested a period of three or four months to bring the property into compliance. She explained that she is only able to work on the property one day per week due to her full-time work schedule of five days a week.

Director Towles stated that simply installing a fence would not fully address the environmental concerns on the property. He added that the City is willing to work with Ms. Barnes to identify potential assistance in bringing the property into compliance.

**SPECIAL MAGISTRATE MAWHINNEY** accepted the photographs into evidence. He found the violation to exist. He gave the property owner ninety (90) days to bring the property into compliance, or a fine of \$100 per day would be imposed. He authorized to abate the violation named herein accordance with 162.09(1), Fla, Stat. The City's current administrative cost of \$78.62 for prosecuting the case was imposed and is payable within thirty (30) days.

- e. **CASE NO. 25-0187-LH**  
**RESPONDENT: RANDALL DOUGLAS NEWMAN**  
**LOCATION: 680 GARDEN ST.**  
**VIOLATION(S):**  
**1.MPMS 302.7 ACCESSORY STRUCTURE**

Code Compliance Inspector Hodge personally took the photographs associated with this case, and they accurately depicted what she saw. During routine patrol, she found the above violation to exist. On November 18, 2025, a Notice of Violation was posted on the subject property, and City Hall and mailed via certified and first-class mail giving the property owner thirty (30) days to come into compliance. Prior to reinspection date on December 20, 2025, the respondent phoned and requested an extension, a new compliance date was set for February 1, 2026. Upon reinspection on February 1, 2026, violations were not corrected. Spoke with respondent on February 5, 2026, at 9:40 am, who stated she lost her cat, had been depressed and that it has been too cold. I provided an additional 30-day extension advising respondent progress would need to be made in order to avoid further enforcement actions. The new inspection date was set for March 7, 2026. The property was reinspected on March 9, 2026, and the violation was not corrected. The City has incurred the investigative costs of \$157.24. She requests the property owner be given thirty (30) days to come into compliance, or be fined \$150 per day, plus associated city costs.

The Respondent(s), Randall Douglas Newman, was duly served with notice of the subject hearing and did not attend this hearing. Attorney Melissa Wilson was present representing property owner Tina Barnes.

**SPECIAL MAGISTRATE MAWHINNEY** accepted the photographs into evidence. He found the violation to exist. He gave the property owner ninety (90) days to bring the property into compliance, or a fine of \$150 per day would be imposed. He authorized to abate the violation named herein accordance with 162.09(1), Fla, Stat. The City's current administrative cost of \$78.62 for prosecuting the case was imposed and is payable within thirty (30) days.

**9. REPEAT VIOLATIONS – None**

**10. DEMOLITION REQUESTS – None**

**11. REDUCTION REQUESTS - None**

**12. ADJOURNMENT**

With no further business, Special Magistrate Mawhinney adjourned the hearing at 9:36 a.m.

\_\_\_\_\_  
Special Magistrate Joseph Mawhinney

Attest:

\_\_\_\_\_  
Assistant City Clerk Kaylee Fussell

(seal)

DRAFT

**IN AND FOR THE CITY OF BARTOW, FLORIDA**

**CASE NO.: 25-0117**

**IN RE: 470 Shady Lane ST BARTOW FL 33830**

**25-30-06-385700-005020**

**RICHLAND MANOR REPLAT OF BLKS E & F UNIT 1 PB 42 PG 24 BLK E LOT 2, as recorded in the Public Records of Polk County, Florida**

**CITY OF BARTOW, a Florida municipal corporation,  
Petitioner**

**v.**

**Lance Fagan,  
Respondent(s).**

\_\_\_\_\_ /

**AFFIDAVIT OF SERVICE**

I, **Laporchia Hodge**, Code Enforcement Director, state as follows:

1. On 04/16/2026, I sent a copy of:

- Notice of Violation
- Notice of Hearing
- Notice of Hearing: Certification of Fines
- Notice and Order of Demolition
- Order Finding Violation
- Order Imposing Fine

- Affidavit of:  Non-Compliance  Compliance
- Order Authorizing Initiation of Demolition Process
  - Final Order Authorizing Demolition of Structure
  - Order on Request to Reduce Fine
  - Other: \_\_\_\_\_

Via  Certified Mail  First Class Mail  Other: \_\_\_\_\_

to the property owner(s) at the address mailing address listed on the Polk County Property Appraiser's website:  
**Address: 470 Shady Lane BARTOW FL 33830-3354**

- 2. On 04/16/2026, I posted a copy of the same at the above-described property; and
- 3. On 04/16/2026, I posted a copy of the same at City Hall.
- 4. Alternatively, I hand delivered a copy of the same to the property owner(s) on \_\_\_\_\_ as attested to by the following signature: \_\_\_\_\_

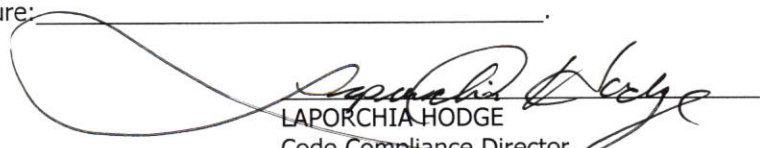
  
 LAPORCHIA HODGE  
 Code Compliance Director

STATE OF FLORIDA  
COUNTY OF POLK

I HEREBY CERTIFY that on this day, before me, by means of  physical presence or \_\_\_ online notarization, an officer duly authorized to administer oaths and take acknowledgements, personally appeared Lance Fagan, who is personally known to me to be the person described in and who executed the foregoing instrument, and who, being sworn by me, acknowledged before me the execution of same.

WITNESS, my hand and official seal in the County and State last aforesaid this 16th Day of April, 2026.

 Notary Public

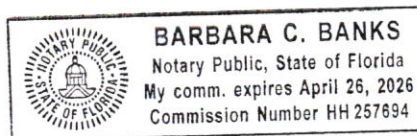

5270 3573 0467 55

**U.S. Postal Service™**  
**CERTIFIED MAIL® RECEIPT**  
*Domestic Mail Only*

For delivery information, visit our website at [www.usps.com](http://www.usps.com)®.

**OFFICIAL USE**

Certified Mail Fee	\$
Extra Services & Fees (check box, add fee as appropriate)	
<input type="checkbox"/> Return Receipt (hardcopy)	\$ _____
<input type="checkbox"/> Return Receipt (electronic)	\$ _____
<input type="checkbox"/> Certified Mail Restricted Delivery	\$ _____
<input type="checkbox"/> Adult Signature Required	\$ _____
<input type="checkbox"/> Adult Signature Restricted Delivery	\$ _____
Postage	

25.0117 PH  
COF  
Postmark  
Here

Lance Fagan  
470 Shady Lance  
Bartow, FL. 33830

**IN AND FOR THE CITY OF BARTOW, FLORIDA**

**CASE NO.: 25-0117**

**IN RE: 470 Shady Lane, FL 33830  
25-30-06-3857000-005020  
RICHLAND MANOR REPLAT OF BLKS E & F UNIT 1 PB 42 PG 24 BLK E LOT 2,  
PUBLIC RECORDS OF POLK COUNTY, FLORIDA.**

**CITY OF BARTOW, a Florida municipal corporation,  
Petitioner**

**v.**

**Lance Fagan,  
Respondent(s).**

**NOTICE OF HEARING  
CERTIFICATION OF FINES**

---

You are hereby notified that on April 28, 2026, at 9:00 A.M. in City Commission Chambers, in City Hall, located at 450 N. Wilson Avenue, Bartow, Florida, a Hearing will be held before the City of Bartow Special Magistrate to consider an Affidavit of Non-Compliance and Fine Certifications for violations at the above-referenced address.

Please be advised that the procedures of the Hearing are governed by the Rules of the Special Magistrate and the Code of Ordinances of the City of Bartow. Copies of these Rules and Ordinances may be obtained at Office of the City Clerk, City of Bartow. PLEASE GOVERN YOURSELF ACCORDINGLY.

**FAILURE TO APPEAR AT THE TIME SET CAN RESULT IN AN ORDER BEING ENTERED IN ABSENTIA AND A LIEN AGAINST YOUR REAL OR PERSONAL PROPERTY BEING ENTERED, WHICH MAY CAUSE LEVY AGAINST PERSONAL PROPERTY OR FORECLOSURE ON REAL PROPERTY.**

The burden is upon the Respondent to request a re-inspection to determine if the property has been brought into compliance. If you have any questions regarding this notice or need to schedule a re-inspection, call the Office of Code Compliance & Neighborhood Services at **863-534-0100**.

April 16, 2026  
Date

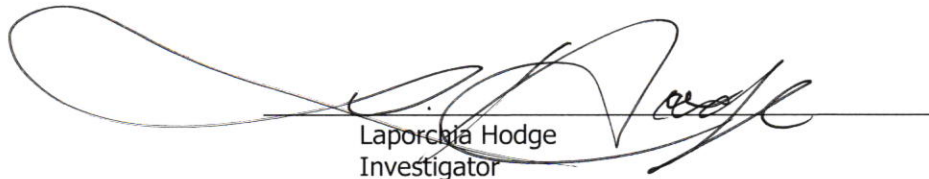

Laporchia Hodge  
Investigator

Office of Code Compliance & Neighborhood Services

**VIOLATION COURT PACKET**  
April 17, 2026

Violation Number : 25-0117	Original Complaint Number:
Parcel Number: 253006385700005020	Original Failed Inspection Number:
Owner Name: FAGAN LANCE	Required Resolve By Date: February 24, 2026
Occupant Name: FAGAN LANCE	Violation Status: Closed - Warning to Notice to Hearing Violation Type: Code Enforcement
Parcel Address: SHADY 470 LN - Unit ID:	Violation Date: November 4, 2025      Violation Time: 11:40AM

Violation Description: Rusted ramp observed out front in driveway.

**Code Book:** 2021 International Property Maintenance Code - Code Title: Section 302.1: Sub-Section: IPMC2021P2\_Ch03\_Sec302.1 Sanitation. - Code Section: 302.1

**Ordinance:** Exterior property and premises shall be maintained in a clean, safe and sanitary condition. The occupant shall keep that part of the exterior property that such occupant occupies or controls in a clean and sanitary condition.

No owner or occupant shall permit old or broken lumber, rusted or unused equipment, discarded refrigerators, discarded stoves, old pipe or other used, discarded and worn, unsightly articles or materials to remain in any yard or open area owned, occupied or in the possession of such person for a period of more than five (5) days.

Further, unless authorized by the zoning category of the property, no owner or occupant of a building, structure or premises may utilize such property for the open storage of abandoned, untagged, or inoperative motor vehicles, iceboxes, refrigerators, stoves, glass, building material rubbish or similar items.

**Conditions Found and Corrective Action Required: Remove rusted, unused ramp from driveway. Store in garage or remove from premises altogether.**

**Code Book:** Code of Ordinance, Municode - Code Title: Section Sec. 18-17.: Sub-Section:

PTIICOOR\_CH18BUBURE\_ARTIIMIPRMAST\_S18-17OUSTDEPRPR Outdoor storage of derelict property prohibited. - Code Section: Sec. 18-17.

**Ordinance:** (a)

For purposes of this section:

Derelict property means one or more pieces of inoperable automotive or marine machinery, one or more inoperable household appliances or accumulations of scrap metal, plastic or other junk materials.

Inoperable means either malfunctioning, broken, wrecked, partially dismantled, in a current state of disrepair or unable to be used in the manufacturer's intended manner because of a legal infirmity.

Temporarily means a reasonable period of time under the circumstances, but shall in no case exceed 21 days.

(b)

It is illegal for a person to store derelict property or allow derelict property to be stored in the city unless such property:

(1)

Is stored within a fully enclosed and lawfully constructed building;

(2)

Is stored on the premises of a business enterprise engaged in commerce related to the sale or repair of derelict property, provided that if the business is an automotive or marine repair or storage facility that the derelict property is not stored outdoors for more than 180 total days;

(3)

Is stored by a government agency on government-owned property; or

(4)

Is stored temporarily on real property owned by the derelict property's owner during such time as repairs to the derelict property are being pursued with due diligence

provided that the necessary repair work does not constitute a nuisance to others and all other applicable laws are followed.

(c)

Derelict property may be removed and impounded by the city at its option. If derelict property is so impounded, the owner of the same will be responsible for payment of all city-incurred storage and transportation costs prior to its release. Before removal, the city shall give ten days' notice to either:

(1)

The owner of the realty where such derelict property is situated by certified mail, return receipt requested; or

(2)

To the general public by placarding such property with a warning on bright colored heavy stock paper that states the date of issuance and the date of the end of the ten-day notice period.

Before the expiration of the notice period, the derelict property's owner may petition the city for a hearing before the city manager or his or her designee by filing a written request for the same with the city clerk. The factual issues to be decided at hearing shall be limited to whether or not the subject property qualifies as derelict property and whether or not a valid storage exception applies. Once rendered, the city manager's decision is final.

(d)

The outdoor storage of derelict property shall constitute cause for the city to proceed with removal and impoundment pursuant to this section. The burden of proof that derelict property is subject to a storage exception shall lie with the derelict property's owner.

(Ord. No. 2012-07, Â§Â§ 2, 3(Exh. A), 8-6-12)

**Conditions Found and Corrective Action Required: Remove rusted, unused ramp from driveway. Store in garage or remove from premises altogether**

Listing of All Actions Related to Violation Number: 25-0117

November 4, 2025 11:44AM **Violation Created**

Violation Created For Parcel #253006385700005020

November 4, 2025 11:49AM **Inspection #25-0107 - Scheduled**

Inspection #25-0107 has been scheduled for this violation.

December 5, 2025 09:56AM **Inspection #25-0107 Result - Fail**

Inspection #25-0107 was marked as failed for this violation.

January 8, 2026 10:41AM **Inspection #26-0028 - Scheduled**

Inspection #26-0028 has been scheduled for this violation.

January 8, 2026 10:44AM **Inspection #26-0029 Result - Fail**

Inspection #26-0029 has been scheduled for this violation.

January 8, 2026 10:55AM **Set for hearing**

Certified Mail Receipt 70202450000049449875

February 5, 2026 01:40PM **Inspection #26-0079 Result - Fail**

Inspection #26-0079 has been scheduled for this violation.

February 23, 2026 11:00AM **Inspection #26-0134 Result - Fail**

Inspection #26-0134 has been scheduled for this violation.

February 24, 2026 08:19AM **Inspection #26-0135 Result - Fail**

Inspection #26-0135 has been scheduled for this violation.

April 16, 2026 10:55AM **Court Action**

Certification of fines mailed. Cert mail #9589071052703573046755

Listing of All Tickets Issued:

---

Listing of All Images on File Relating to Case:

**Tax Parcel #:** 253006385700005020

**Address:** SHADY 470 LN

**Violation #:** 25-0117

**Upload Date:** December 8, 2025 03:32PM



**Tax Parcel #:** 253006385700005020

**Address:** SHADY 470 LN

**Violation #:** 25-0117

**Upload Date:** December 8, 2025 03:32PM



**Tax Parcel #:** 253006385700005020

**Address:** SHADY 470 LN

**Violation #:** 25-0117

**Upload Date:** December 8, 2025 03:33PM



**Tax Parcel #:** 253006385700005020  
**Address:** SHADY 470 LN  
**Violation #:** 25-0117  
**Upload Date:** December 8, 2025 03:33PM



**Tax Parcel #:** 253006385700005020  
**Address:** SHADY 470 LN  
**Violation #:** 25-0117  
**Upload Date:** January 8, 2026 03:21PM

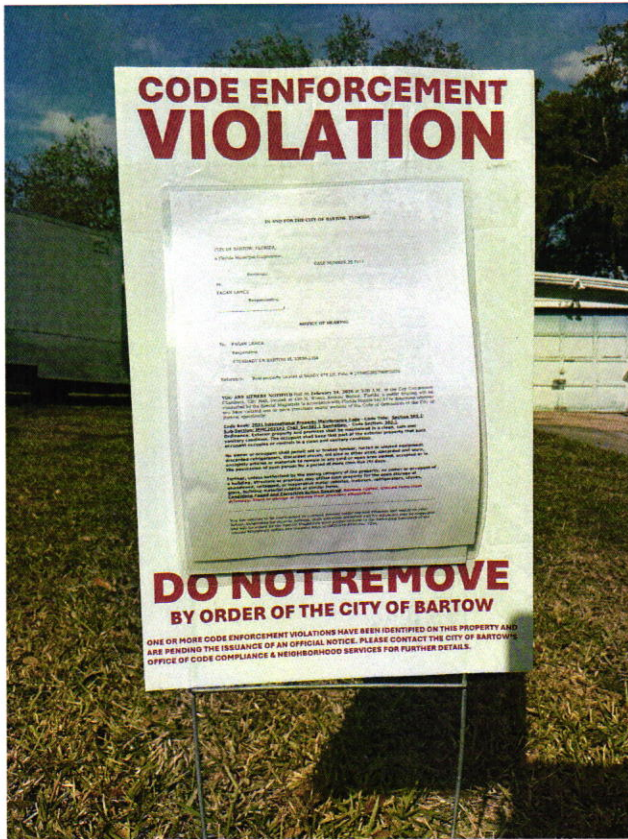

**Tax Parcel #:** 253006385700005020  
**Address:** SHADY 470 LN  
**Violation #:** 25-0117  
**Upload Date:** January 8, 2026 03:21PM



**Tax Parcel #:** 253006385700005020  
**Address:** SHADY 470 LN  
**Inspection #:** 25-0107  
**Inspection Date:** December 5, 2025 11:45AM  
**Upload Date:** December 5, 2025 09:56AM



**Tax Parcel #:** 253006385700005020  
**Address:** SHADY 470 LN  
**Inspection #:** 25-0107  
**Inspection Date:** December 5, 2025 11:45AM  
**Upload Date:** December 5, 2025 09:56AM



**Tax Parcel #:** 253006385700005020  
**Address:** SHADY 470 LN  
**Inspection #:** 26-0134  
**Inspection Date:** February 23, 2026 10:55AM  
**Upload Date:** February 23, 2026 11:01AM



**Tax Parcel #:** 253006385700005020  
**Address:** SHADY 470 LN  
**Inspection #:** 26-0134  
**Inspection Date:** February 23, 2026 10:55AM  
**Upload Date:** February 23, 2026 11:01AM



**Tax Parcel #:** 253006385700005020  
**Address:** SHADY 470 LN  
**Inspection #:** 26-0135  
**Inspection Date:** February 24, 2026 08:20AM  
**Upload Date:** February 24, 2026 08:19AM



*Bela E. Park*  
\_\_\_\_\_  
Signature of Person Preparing Packet

*4/17/25*  
\_\_\_\_\_  
Date

# Parcel Details: 25-30-06-385700-005020

## Owners *Recently purchased this property? Click here.*

FAGAN LANCE 100%

## Mailing Address *(Address Change form)*

470 SHADY LN  
BARTOW FL 33830-3354

## Physical Street Address *Why postal city and municipality? Click here.*

470 SHADY LN

## Postal City and Zip

BARTOW FL 33830

## Parcel Information

Municipality **BARTOW (Code: 90310)**  
**430232.00**  
 Neighborhood [Search Recent Sales in this Neighborhood](#)  
 Subdivision **RICHLAND MANOR UNIT NO 1 REPLAT BLKS E &**  
 Property (DOR) Use Code **SFR up to 2.49 AC (Code: 0100)**  
 Acreage **0.22**  
 Community Redevelopment Area **NOT IN CRA**

## Property Desc

**DISCLAIMER:** The property description provided is a summary of the original legal description and should not be used for conveying property, as it may render the deed invalid.

## Area Map

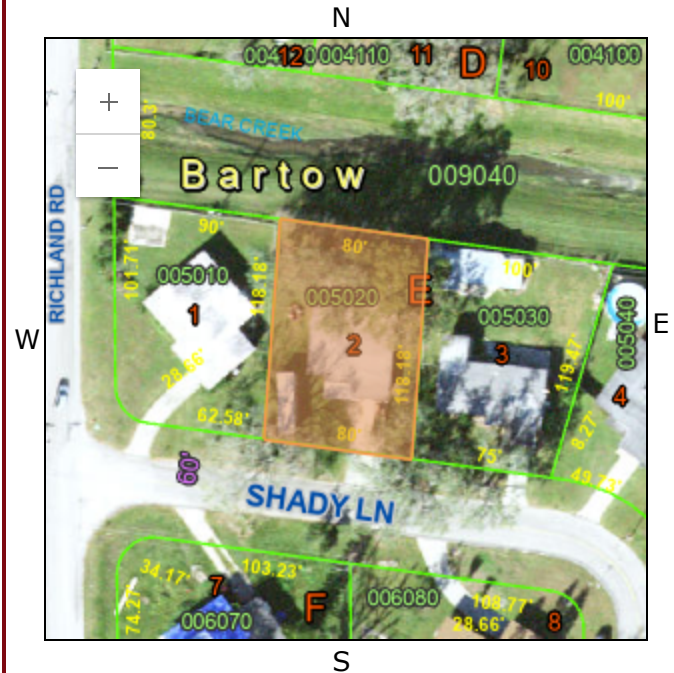

## Recorded Plat

[Recorded Plat for this parcel](#)

## Section Maps for 253006

[HTML \(opens in new tab\)](#)

[Printable PDF](#)

## Sales History

**Important Notice:** If you wish to obtain a copy of a deed for this parcel, click on the blue OR Book/Page number. If the Book/Page number does not have a blue link or if the document is restricted, it may not be available online. Please contact the Polk County Clerk Indexing Department at 863-534-4516. If the Type Inst is an "R", please contact the Property Appraiser at 863-534-4765 to order "R" type instruments.

OR Book/Page	Date	Type Inst	Vacant/ Improved	Grantee	Sales Price
<a href="#">7169/1720</a>	02/2007	W	I	FAGAN LANCE	\$129,000
<a href="#">6927/1107</a>	08/2006	W	I	SECRETARY OF HOUSING AND URBAN	\$100

6864/1237	07/2006	CT	I	MIDFIRST BANK	\$100
3753/1968	10/1996	Q	I		\$10
1063/0153	02/1966		E		\$11,000

## Exemptions

**Note:** The drop down menus below provide information on the amount of exemption applied to each taxing district. The HX—first \$25,000 homestead exemption may be allocated to one or more owners. The HB second amended homestead exemption reflects the name of the first owner only.

Bld. Code #	Description	% Ownership	Renew Cd	Year	Name	Note	Value
☒ HX	HX-HOMESTEAD-FS196.031(1)(A)	100%	2009		FAGAN LANCE		\$25,000
☒ HB	AMENDED HOMESTEAD	100%	2009		FAGAN LANCE		\$0
<b>Total Exemption Value (County)</b>							<b>\$25,000</b>

## Buildings

### BUILDING 1 (SF - Single Family)

#### Building Characteristics

**Living Area:** 1,000 sqft  
**Total Under Roof:** 2,221 sqft  
**Actual Year Built:** 1958  
**Building Value:** \$214,293

Element	Units	Information
BEDROOM	3	
FULL BATH	2	
HALF BATH	0	
FIREPLACE	N	
CNTRL HEATING / AC	Y	
STYLE		SINGLE FAMILY
UNITS		1 UNIT
STORY HEIGHT INFO ONLY		1 STORY FOR INFO ONLY
SUBSTRUCT		CONTINUOUS WALL
FRAME / CONST TYPE		MASONRY/BLOCK
EXTERIOR WALL		UNFINISHED
ROOF STRUCTURE		GABLE-METAL

#### 470 SHADY LN

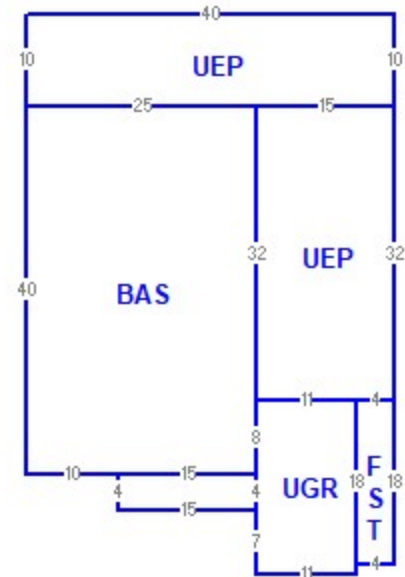

View Larger: [Double](#) - [Quadruple](#)  
 Effective Year: 1958

#### Building Subareas

Code/Description	Heated	Total
BASE AREA	Y	1,000
UEP UNFIN. ENCL PORCH		400
UEP UNFIN. ENCL PORCH		480
FST FINISHED UTILITY		72
UOP UNFIN. OPEN PORCH		60
UGR UNFINISHED GARAGE		209
<b>Total Under Roof</b>		<b>2,221 SQ FT</b>

**Extra Features (Current)**

LN	Code	Description	BLD	Length	Width	Units	Year Built
1	SCR1	SCREEN ROOM AVG QUAL; 200 SF OR LESS	1	0	0	1	2003

**PERMITS**

Please contact the [appropriate permit issuing agency](#) to obtain information. This property is located in the **BARTOW** taxing district.

**Land Lines**

LN	Land Description	Ag/GreenBelt	Land Unit Type	Front	Depth	Units
1	* WATER INFLUENCE	N	UNIT	0	0	1.00

\* For Zoning/Future Land Use contact Polk County or the Municipality the parcel is located in.

**NOTICE: All information ABOVE this notice is current (as of Friday, April 17, 2026 at 2:09:46 AM). All information BELOW this notice is from the 2025 Tax Roll, except where otherwise noted.**

**Value Summary (2025)**

Desc	Value
LAND VALUE	\$24,000
BUILDING VALUE	\$214,293
EXTRA FEATURES VALUE	\$1,000
JUST MARKET VALUE	\$239,293
AG CLASSIFIED LAND VALUE	\$0
AGRICULTURE CLASSIFICATION SAVINGS	\$0
*HOMESTEAD CAP AND SOH PORTABILITY SAVINGS	\$191,100
ASSESSED VALUE	\$48,193
EXEMPTION VALUE (COUNTY)	\$25,000
TAXABLE VALUE (COUNTY)	\$23,193

\*This property contains a Homestead Cap with a differential of \$191,100.

**Values by District (2025)**

District Description	Just Market Value	Assessed Value	Exemption	Final Tax Savings	Taxable Value	Final Tax Rate	Final Taxes
BOARD OF COUNTY COMMISSIONERS	\$239,293	\$48,193	\$25,000	\$165.87	\$23,193	6.634800	\$153.88
POLK COUNTY SCHOOL BOARD - STATE	\$239,293	\$48,193	\$25,000	\$76.05	\$23,193	3.042000	\$70.55
POLK COUNTY SCHOOL	\$239,293	\$48,193	\$25,000	\$56.20	\$23,193	2.248000	\$52.14

BOARD -  
LOCAL

CITY OF BARTOW	\$239,293	\$48,193	\$25,000	\$152.70	\$23,193	6.108000	\$141.66
SOUTHWEST FLA WATER MGMT DIST	\$239,293	\$48,193	\$25,000	\$4.58	\$23,193	0.183100	\$4.25

**Tax Savings: \$455.40      Total Taxes: \$422.48**

**Non-Ad Valorem Assessments (2025)**

LN	Code	Desc	Units	Rate	Assessment
1	FC310	BARTOW FIRE SERVICES	1.00	266.21	\$266.21
2	ST310	BARTOW STORMWATER	1.00	134.88	\$134.88
<b>Total Assessments</b>					<b>\$401.09</b>

**Taxes**

Desc	Last Year (2024)	2025 Final
Taxing District	BARTOW/SWFWMD (Code: 90310)	BARTOW/SWFWMD (Code: 90310)
Millage Rate	18.2297	18.2159
Ad Valorem Assessments	\$398.05	\$422.48
Non-Ad Valorem Assessments	\$384.48	\$401.09
<b>Total Taxes</b>	<b>\$782.53</b>	<b>\$823.57</b>

**Your final tax bill may contain Non-Ad Valorem assessments which may not be reflected on this page, such as assessments for roads, drainage, garbage, fire, lighting, water, sewer, or other governmental services and facilities which may be levied by your county, city or any other special district. [Visit the Polk County Tax Collector's site for Tax Bill information related to this account.](#) Use "[Property Tax Estimator](#) to estimate taxes for this account.**

**Prior Year Final Values**

The Final Tax Roll is the 1st certification of the tax rolls by the Value Adjustment Board, [per Florida Statute 193.122\(2\), F.S.](#) This is the date all taxable property and tax rolls are certified for collection to the Tax Collector. Corrections made after this date are not reflected in the Final Tax Roll Values.

DESCRIPTION	2024	2023	2022	2021
LAND VALUE	\$24,000.00	\$23,000.00	\$19,000.00	\$17,500.00
BUILDING VALUE	\$219,045.00	\$208,993.00	\$178,805.00	\$138,112.00
EXTRA FEATURES VALUE	\$1,000.00	\$1,000.00	\$1,000.00	\$1,000.00
JUST MARKET VALUE	\$244,045.00	\$232,993.00	\$198,805.00	\$156,612.00
HOMESTEAD CAP AND SOH PORTABILITY SAVINGS	\$197,210.00	\$187,522.00	\$154,658.00	\$113,751.00
ASSESSED VALUE	\$46,835.00	\$45,471.00	\$44,147.00	\$42,861.00
EXEMPTION VALUE (COUNTY)	\$25,000.00	\$25,000.00	\$25,000.00	\$25,000.00
TAXABLE VALUE (COUNTY)	\$21,835.00	\$20,471.00	\$19,147.00	\$17,861.00

**DISCLAIMER:**

The Polk County Property Appraiser makes no representations or warranties regarding the completeness and accuracy of the data herein, its use or interpretation, the fee or beneficial/equitable title ownership or encumbrances of the property, and assumes no liability associated with its use or misuse. See the posted Site Notice.



**IN AND FOR THE CITY OF BARTOW, FLORIDA**

**CASE NO.: 26-0111**

**IN RE: 2015 Laurel St.**

**25-30-09-000000-033090**

**N 93.59 FT OF W 66 FT OF 1 AC OFF E END OF N1/2 OF S1/2 OF NE1/4 OF NW1/4 OF NW1/4 LESS N 20 FT FOR LAUREL ST, as recorded in the Public Records of Polk County, Florida**

**CITY OF BARTOW, a Florida municipal corporation,  
Petitioner**

**v.**

**Frances Radford,  
Respondent(s).**

\_\_\_\_\_

**AFFIDAVIT OF SERVICE**

I, **Delaila S Tait**, Code Enforcement Investigator, state as follows:

1. On 2/19/2026, I sent a copy of:

- Notice of Violation
- Notice of Hearing
- Notice of Hearing: Certification of Fines
- Notice and Order of Demolition
- Order Finding Violation
- Order Imposing Fine

- Affidavit of:  Non-Compliance  Compliance
- Order Authorizing Initiation of Demolition Process
  - Final Order Authorizing Demolition of Structure
  - Order on Request to Reduce Fine
  - Other: \_\_\_\_\_

Via  Certified Mail  First Class Mail  Other: \_\_\_\_\_

to the property owner(s) at the address mailing address listed on the Polk County Property Appraiser's website:  
**4104 Vicotria Blvd Hampton VA 23669-4242**

2. On 02/19/2026, I posted a copy of the same at the above-described property; and

3. On 02/19/2026, I posted a copy of the same at City Hall.

4. Alternatively, I hand delivered a copy of the same to the property owner(s) on \_\_\_\_\_ as attested to by the following signature: \_\_\_\_\_

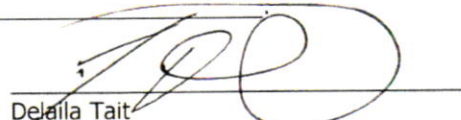
  
\_\_\_\_\_  
Delaila Tait  
Code Compliance Investigator

STATE OF FLORIDA  
COUNTY OF POLK

I HEREBY CERTIFY that on this day, before me, by means of  physical presence or  online notarization, an officer duly authorized to administer oaths and take acknowledgements, personally appeared Delaila S Tait, who is personally known to me to be the person described in and who executed the foregoing instrument, and who, being sworn by me, acknowledged before me the execution of same.

WITNESS my hand and official seal in the County and State last aforesaid this 19th Day of February, 2026. Barbara C. Banks Notary Public

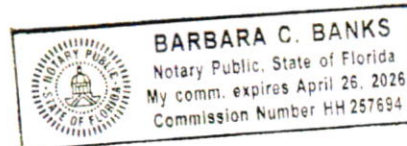

9589 0710 5270 3573 0473 49

**U.S. Postal Service™**  
**CERTIFIED MAIL® RECEIPT**  
*Domestic Mail Only*

For delivery information, visit our website at [www.usps.com](http://www.usps.com)™.

OFFICIAL USE

Certified Mail Fee	
\$	_____
Extra Services & Fees (check box, add fee as appropriate)	
<input type="checkbox"/> Return Receipt (hardcopy)	\$ _____
<input type="checkbox"/> Return Receipt (electronic)	\$ _____
<input type="checkbox"/> Certified Mail Restricted Delivery	\$ _____
<input type="checkbox"/> Adult Signature Required	\$ _____
<input type="checkbox"/> Adult Signature Restricted Delivery	\$ _____

Postmark  
Here

Postage

**Frances Radford**  
**4104 Victoria BLVD**  
**Hampton VA 23669-4242**

**IN AND FOR THE CITY OF BARTOW, FLORIDA**

**CASE NO.: 26-0111**

**IN RE: 2015 Laurel St.**

**25-30-09-000000-033090**

**N 93.59 FT OF W 66 FT OF 1 AC OFF E END OF N1/2 OF S1/2 OF NE1/4 OF NW1/4 OF NW1/4 LESS N 20 FT FOR LAUREL ST, as recorded in the Public Records of Polk County, Florida**

**CITY OF BARTOW, a Florida municipal corporation,  
Petitioner**

**v.  
Frances Radford,  
Respondent(s).**

**AFFIDAVIT OF SERVICE**

I, **Delaila S Tait**, Code Enforcement Investigator, state as follows:

1. On 2/19/2026, I sent a copy of:

- Notice of Violation
- Notice of Hearing
- Notice of Hearing: Certification of Fines
- Notice and Order of Demolition
- Order Finding Violation
- Order Imposing Fine

- Affidavit of:  Non-Compliance  Compliance
- Order Authorizing Initiation of Demolition Process
  - Final Order Authorizing Demolition of Structure
  - Order on Request to Reduce Fine
  - Other: \_\_\_\_\_

Via  Certified Mail  First Class Mail  Other: \_\_\_\_\_

to the property owner(s) at the address mailing address listed on the Polk County Property Appraiser's website:  
**2015 Laurel St E Bartow Fl 33830**

- 2. On 02/19/2026, I posted a copy of the same at the above-described property; and
- 3. On 02/19/2026, I posted a copy of the same at City Hall.
- 4. Alternatively, I hand delivered a copy of the same to the property owner(s) on \_\_\_\_\_ as attested to by the following signature: \_\_\_\_\_

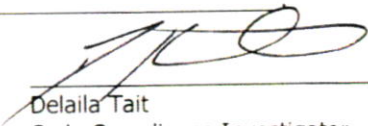
  
\_\_\_\_\_  
Delaila Tait  
Code Compliance Investigator

STATE OF FLORIDA  
COUNTY OF POLK

I HEREBY CERTIFY that on this day, before me, by means of  physical presence or  online notarization, an officer duly authorized to administer oaths and take acknowledgements, personally appeared Delaila S Tait, who is personally known to me to be the person described in and who executed the foregoing instrument, and who, being sworn by me, acknowledged before me the execution of same.

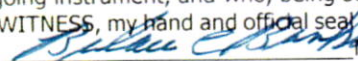
WITNESS, my hand and official seal in the County and State last aforesaid this 19th Day of February, 2026.  Notary Public

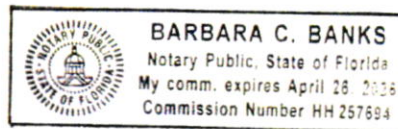

9589 0710 5270 3573 0472 40

**U.S. Postal Service™**  
**CERTIFIED MAIL® RECEIPT**  
*Domestic Mail Only*

For delivery information, visit our website at [www.usps.com](http://www.usps.com)®.

OFFICIAL USE

Certified Mail Fee	
\$	
Extra Services & Fees (check box, add fee as appropriate)	
<input type="checkbox"/> Return Receipt (hardcopy)	\$ _____
<input type="checkbox"/> Return Receipt (electronic)	\$ _____
<input type="checkbox"/> Certified Mail Restricted Delivery	\$ _____
<input type="checkbox"/> Adult Signature Required	\$ _____
<input type="checkbox"/> Adult Signature Restricted Delivery	\$ _____

Postmark  
Here

Frances Radford  
2015 Laurel St E  
Bartow FL 33830

**IN AND FOR THE CITY OF BARTOW, FLORIDA**

**CASE NO.: 26-0111**

**IN RE: 2015 Laurel St.**

**25-30-09-000000-033090**

**N 93.59 FT OF W 66 FT OF 1 AC OFF E END OF N1/2 OF S1/2 OF NE1/4 OF NW1/4 OF NW1/4 LESS N 20 FT FOR LAUREL ST, as recorded in the Public Records of Polk County, Florida**

**CITY OF BARTOW, a Florida municipal corporation,  
Petitioner**

v.

**Yvonne, Reginald, Fredrick, Andrea, Ronald, Warren, and Aaron Washington,  
Respondent(s).**

**AFFIDAVIT OF SERVICE**

I, **Delaila S Tait**, Code Enforcement Investigator, state as follows:

1. On 2/19/2026, I sent a copy of:

- Notice of Violation
- Notice of Hearing
- Notice of Hearing: Certification of Fines
- Notice and Order of Demolition
- Order Finding Violation
- Order Imposing Fine

- Affidavit of:  Non-Compliance  Compliance
- Order Authorizing Initiation of Demolition Process
  - Final Order Authorizing Demolition of Structure
  - Order on Request to Reduce Fine
  - Other: \_\_\_\_\_

Via  Certified Mail  First Class Mail  Other: \_\_\_\_\_

to the property owner(s) at the address mailing address listed on the Polk County Property Appraiser's website:  
**4104 Vicotria Blvd Hampton VA 23669-4242**

2. On 02/19/2026, I posted a copy of the same at the above-described property; and

3. On 02/19/2026, I posted a copy of the same at City Hall.

4. Alternatively, I hand delivered a copy of the same to the property owner(s) on \_\_\_\_\_ as attested to by the following signature: \_\_\_\_\_

  
\_\_\_\_\_  
Delaila Tait  
Code Compliance Investigator

STATE OF FLORIDA  
COUNTY OF POLK

I HEREBY CERTIFY that on this day, before me, by means of  physical presence or  online notarization, an officer duly authorized to administer oaths and take acknowledgements, personally appeared Delaila S Tait, who is personally known to me to be the person described in and who executed the foregoing instrument, and who, being sworn by me, acknowledged before me the execution of same.

WITNESS, my hand and official seal in the County and State last aforesaid this 19th Day of February, 2026. Barbara C Banks Notary Public

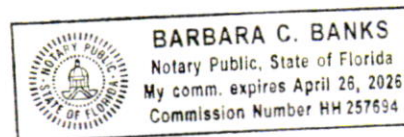

9589 0710 5270 3573 0473 32

**U.S. Postal Service™**  
**CERTIFIED MAIL® RECEIPT**  
*Domestic Mail Only*

For delivery information, visit our website at [www.usps.com](http://www.usps.com)™.

OFFICIAL USE

Certified Mail Fee	
\$	_____
Extra Services & Fees (check box, add fee as appropriate)	
<input type="checkbox"/> Return Receipt (hardcopy)	\$ _____
<input type="checkbox"/> Return Receipt (electronic)	\$ _____
<input type="checkbox"/> Certified Mail Restricted Delivery	\$ _____
<input type="checkbox"/> Adult Signature Required	\$ _____
<input type="checkbox"/> Adult Signature Restricted Delivery	\$ _____

Postmark  
Here

Yvonne, Reginald, Fredrick, Andrea  
Ronald, Warren, and Aaron Washington  
4104 Victoria BLVD  
Hampton VA 23669-4242

PS Form 3800, January 2023 PSN 7530-02-000-9047 See Reverse for Instructions

IN AND FOR THE CITY OF BARTOW, FLORIDA

CASE NO.: 26-0111

IN RE: 2015 Laurel St.

25-30-09-000000-033090

N 93.59 FT OF W 66 FT OF 1 AC OFF E END OF N1/2 OF S1/2 OF NE1/4 OF NW1/4 OF NW1/4 LESS N 20 FT FOR LAUREL ST, as recorded in the Public Records of Polk County, Florida

CITY OF BARTOW, a Florida municipal corporation,
Petitioner

v.

Marion Motley,
Respondent(s).

AFFIDAVIT OF SERVICE

I, Delaila S Tait, Code Enforcement Investigator, state as follows:

1. On 2/19/2026, I sent a copy of:

- Notice of Violation
Notice of Hearing
Notice of Hearing: Certification of Fines
Notice and Order of Demolition
Order Finding Violation
Order Imposing Fine

- Affidavit of: Non-Compliance Compliance
Order Authorizing Initiation of Demolition Process
Final Order Authorizing Demolition of Structure
Order on Request to Reduce Fine
Other:

Via Certified Mail First Class Mail Other:

to the property owner(s) at the address mailing address listed on the Polk County Property Appraiser's website:
4104 Vicotria Blvd Hampton VA 23669-4242

- On 02/19/2026, I posted a copy of the same at the above-described property; and
On 02/19/2026, I posted a copy of the same at City Hall.
Alternatively, I hand delivered a copy of the same to the property owner(s) on as attested to by the following signature:

Delaila Tait
Code Compliance Investigator

STATE OF FLORIDA
COUNTY OF POLK

I HEREBY CERTIFY that on this day, before me, by means of physical presence or online notarization, an officer duly authorized to administer oaths and take acknowledgements, personally appeared Delaila S Tait, who is personally known to me to be the person described in and who executed the foregoing instrument, and who, being sworn by me, acknowledged before me the execution of same.

WITNESS, my hand and official seal in the County and State last aforesaid this 19th Day of February, 2026. Notary Public

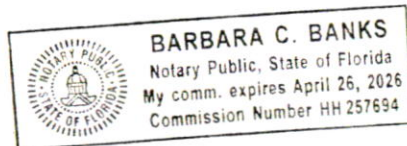

9589 0710 5270 3573 0473 56

**U.S. Postal Service™**  
**CERTIFIED MAIL® RECEIPT**  
*Domestic Mail Only*

For delivery information, visit our website at [www.usps.com](http://www.usps.com)®.

OFFICIAL USE

Certified Mail Fee	\$
Extra Services & Fees (check box, add fee as appropriate)	
<input type="checkbox"/> Return Receipt (hardcopy)	\$ _____
<input type="checkbox"/> Return Receipt (electronic)	\$ _____
<input type="checkbox"/> Certified Mail Restricted Delivery	\$ _____
<input type="checkbox"/> Adult Signature Required	\$ _____
<input type="checkbox"/> Adult Signature Restricted Delivery	\$ _____

Postmark  
Here

Post	
\$ Totl	Marion Motley
\$ Ser	4104 Victoria BLVD
Str	Hampton VA 23669-4242
City	

PS Form 3800, January 2023 PSN 7530-02-000-9047 See Reverse for Instructions

**IN AND FOR THE CITY OF BARTOW, FLORIDA**

**CASE NO.: 26-0111**

**IN RE: 2015 Laurel St.**

**25-30-09-000000-033090**

**N 93.59 FT OF W 66 FT OF 1 AC OFF E END OF N1/2 OF S1/2 OF NE1/4 OF NW1/4 OF NW1/4 LESS N 20 FT FOR LAUREL ST, as recorded in the Public Records of Polk County, Florida**

**CITY OF BARTOW, a Florida municipal corporation,  
Petitioner**

**v.  
Marion Motley,  
Respondent(s).**

**AFFIDAVIT OF SERVICE**

I, **Delaila S Tait**, Code Enforcement Investigator, state as follows:

1. On 2/19/2026, I sent a copy of:

- Notice of Violation
- Notice of Hearing
- Notice of Hearing: Certification of Fines
- Notice and Order of Demolition
- Order Finding Violation
- Order Imposing Fine

- Affidavit of:  Non-Compliance  Compliance
- Order Authorizing Initiation of Demolition Process
  - Final Order Authorizing Demolition of Structure
  - Order on Request to Reduce Fine
  - Other: \_\_\_\_\_

Via  Certified Mail  First Class Mail  Other: \_\_\_\_\_

to the property owner(s) at the address mailing address listed on the Polk County Property Appraiser's website:  
**2015 Laurel St E Bartow Fl 33830**

2. On 02/19/2026, I posted a copy of the same at the above-described property; and

3. On 02/19/2026, I posted a copy of the same at City Hall.

4. Alternatively, I hand delivered a copy of the same to the property owner(s) on \_\_\_\_\_ as attested to by the following signature: \_\_\_\_\_

  
\_\_\_\_\_  
Delaila Tait  
Code Compliance Investigator

STATE OF FLORIDA  
COUNTY OF POLK

I HEREBY CERTIFY that on this day, before me, by means of  physical presence or  online notarization, an officer duly authorized to administer oaths and take acknowledgements, personally appeared Delaila S Tait, who is personally known to me to be the person described in and who executed the foregoing instrument, and who, being sworn by me, acknowledged before me the execution of same.

WITNESS, my hand and official seal in the County and State last aforesaid this 19th Day of February, 2026. Barbara C Banks Notary Public

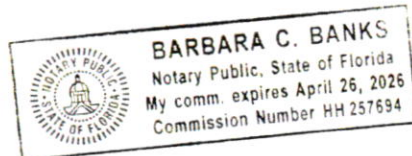

9589 0710 5270 3573 0472 57

**U.S. Postal Service™**  
**CERTIFIED MAIL® RECEIPT**  
*Domestic Mail Only*

For delivery information, visit our website at [www.usps.com](http://www.usps.com)®.

OFFICIAL USE

Certified Mail Fee	\$
Extra Services & Fees (check box, add fee as appropriate)	
<input type="checkbox"/> Return Receipt (hardcopy)	\$ _____
<input type="checkbox"/> Return Receipt (electronic)	\$ _____
<input type="checkbox"/> Certified Mail Restricted Delivery	\$ _____
<input type="checkbox"/> Adult Signature Required	\$ _____
<input type="checkbox"/> Adult Signature Restricted Delivery	\$ _____

Postmark  
Here

Pc: \_\_\_\_\_

\$  
Tot

\$  
Sei

Str: \_\_\_\_\_

Cit: \_\_\_\_\_

Marion Motley  
2015 Laurel St E  
Bartow Fl 33830

IN AND FOR THE CITY OF BARTOW, FLORIDA

CASE NO.: 26-0111

IN RE: 2015 Laurel St.

25-30-09-000000-033090

N 93.59 FT OF W 66 FT OF 1 AC OFF E END OF N1/2 OF S1/2 OF NE1/4 OF NW1/4 OF NW1/4 LESS N 20 FT FOR LAUREL ST, as recorded in the Public Records of Polk County, Florida

CITY OF BARTOW, a Florida municipal corporation,
Petitioner

v.

Tamara Bostic,
Respondent(s).

AFFIDAVIT OF SERVICE

I, Delaila S Tait, Code Enforcement Investigator, state as follows:

1. On 2/19/2026, I sent a copy of:

- Notice of Violation
Notice of Hearing
Notice of Hearing: Certification of Fines
Notice and Order of Demolition
Order Finding Violation
Order Imposing Fine

- Affidavit of: Non-Compliance Compliance
Order Authorizing Initiation of Demolition Process
Final Order Authorizing Demolition of Structure
Order on Request to Reduce Fine
Other:

Via Certified Mail First Class Mail Other:

to the property owner(s) at the address mailing address listed on the Polk County Property Appraiser's website:
4104 Vicotria Blvd Hampton VA 23669-4242

2. On 02/19/2026, I posted a copy of the same at the above-described property; and

3. On 02/19/2026, I posted a copy of the same at City Hall.

4. Alternatively, I hand delivered a copy of the same to the property owner(s) on as
attested to by the following signature:

Handwritten signature of Delaila Tait
Delaila Tait
Code Compliance Investigator

STATE OF FLORIDA
COUNTY OF POLK

I HEREBY CERTIFY that on this day, before me, by means of physical presence or online notarization,
an officer duly authorized to administer oaths and take acknowledgements, personally
appeared Delaila S Tait, who is personally known to me to be the person described in and who executed
the foregoing instrument, and who, being sworn by me, acknowledged before me the execution of same.

WITNESS, my hand and official seal in the County and State last aforesaid this 19th Day of February,
2026. Notary Public

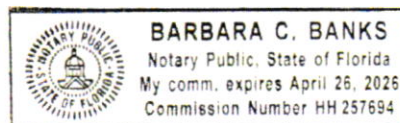

9589 0710 5270 3573 0473 63

**U.S. Postal Service™**  
**CERTIFIED MAIL® RECEIPT**  
*Domestic Mail Only*

For delivery information, visit our website at [www.usps.com](http://www.usps.com)®.

OFFICIAL USE

Certified Mail Fee	
\$	
Extra Services & Fees (check box, add fee as appropriate)	
<input type="checkbox"/> Return Receipt (hardcopy)	\$ _____
<input type="checkbox"/> Return Receipt (electronic)	\$ _____
<input type="checkbox"/> Certified Mail Restricted Delivery	\$ _____
<input type="checkbox"/> Adult Signature Required	\$ _____
<input type="checkbox"/> Adult Signature Restricted Delivery	\$ _____

Postmark  
Here

Tamara Bostic  
4104 Victoria BLVD  
Hampton VA 23669-4242

**IN AND FOR THE CITY OF BARTOW, FLORIDA**

**CASE NO.: 26-0111**

**IN RE: 2015 Laurel St.**

**25-30-09-000000-033090**

**N 93.59 FT OF W 66 FT OF 1 AC OFF E END OF N1/2 OF S1/2 OF NE1/4 OF NW1/4 OF NW1/4 LESS N 20 FT FOR LAUREL ST, as recorded in the Public Records of Polk County, Florida**

**CITY OF BARTOW, a Florida municipal corporation,  
Petitioner**

**v.**

**Tamara Bostic,  
Respondent(s).**

**AFFIDAVIT OF SERVICE**

I, **Delaila S Tait**, Code Enforcement Investigator, state as follows:

1. On 2/19/2026, I sent a copy of:

- Notice of Violation
- Notice of Hearing
- Notice of Hearing: Certification of Fines
- Notice and Order of Demolition
- Order Finding Violation
- Order Imposing Fine

- Affidavit of:  Non-Compliance  Compliance
- Order Authorizing Initiation of Demolition Process
  - Final Order Authorizing Demolition of Structure
  - Order on Request to Reduce Fine
  - Other: \_\_\_\_\_

Via  Certified Mail  First Class Mail  Other: \_\_\_\_\_

to the property owner(s) at the address mailing address listed on the Polk County Property Appraiser's website:  
**2015 Laurel St E Bartow Fl 33830**

2. On 02/19/2026, I posted a copy of the same at the above-described property; and

3. On 02/19/2026, I posted a copy of the same at City Hall.

4. Alternatively, I hand delivered a copy of the same to the property owner(s) on \_\_\_\_\_ as attested to by the following signature: \_\_\_\_\_

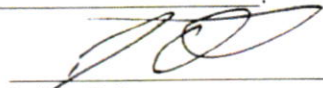
  
\_\_\_\_\_  
Delaila Tait  
Code Compliance Investigator

STATE OF FLORIDA  
COUNTY OF POLK

I HEREBY CERTIFY that on this day, before me, by means of  physical presence or  online notarization, an officer duly authorized to administer oaths and take acknowledgements, personally appeared Delaila S Tait, who is personally known to me to be the person described in and who executed the foregoing instrument, and who, being sworn by me, acknowledged before me the execution of same.

WITNESS my hand and official seal in the County and State last aforesaid this 19th Day of February, 2026. Barbara C Banks Notary Public

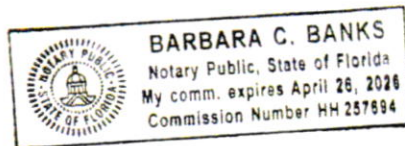

9589 0710 5270 3573 0472 64

**U.S. Postal Service™**  
**CERTIFIED MAIL® RECEIPT**  
*Domestic Mail Only*

For delivery information, visit our website at [www.usps.com](http://www.usps.com)™.

OFFICIAL USE

Certified Mail Fee	
\$	
Extra Services & Fees (check box, add fee as appropriate)	
<input type="checkbox"/> Return Receipt (hardcopy)	\$ _____
<input type="checkbox"/> Return Receipt (electronic)	\$ _____
<input type="checkbox"/> Certified Mail Restricted Delivery	\$ _____
<input type="checkbox"/> Adult Signature Required	\$ _____
<input type="checkbox"/> Adult Signature Restricted Delivery	\$ _____

Postmark  
Here

Postface

Tamara Bostic  
 2015 Laurel St E  
 Bartow Fl 33830

PS Form 3800, January 2023 PSN 753002-000-904 See reverse for instructions

**IN AND FOR THE CITY OF BARTOW, FLORIDA**

**CASE NO.: 26-0111**

**IN RE: 2015 Laurel St.**

**25-30-09-000000-033090**

**N 93.59 FT OF W 66 FT OF 1 AC OFF E END OF N1/2 OF S1/2 OF NE1/4 OF NW1/4 OF NW1/4 LESS N 20 FT FOR LAUREL ST, as recorded in the Public Records of Polk County, Florida**

**CITY OF BARTOW, a Florida municipal corporation,  
Petitioner**

**v.**

**Timothy Bennett,  
Respondent(s).**

**AFFIDAVIT OF SERVICE**

I, **Delaila S Tait**, Code Enforcement Investigator, state as follows:

1. On 2/19/2026, I sent a copy of:

- Notice of Violation
- Notice of Hearing
- Notice of Hearing: Certification of Fines
- Notice and Order of Demolition
- Order Finding Violation
- Order Imposing Fine

- Affidavit of:  Non-Compliance  Compliance
- Order Authorizing Initiation of Demolition Process
  - Final Order Authorizing Demolition of Structure
  - Order on Request to Reduce Fine
  - Other: \_\_\_\_\_

Via  Certified Mail  First Class Mail  Other: \_\_\_\_\_

to the property owner(s) at the address mailing address listed on the Polk County Property Appraiser's website:  
**4104 Vicotria Blvd Hampton VA 23669-4242**

2. On 02/19/2026, I posted a copy of the same at the above-described property; and

3. On 02/19/2026, I posted a copy of the same at City Hall.

4. Alternatively, I hand delivered a copy of the same to the property owner(s) on \_\_\_\_\_ as attested to by the following signature: \_\_\_\_\_

  
\_\_\_\_\_  
Delaila Tait  
Code Compliance Investigator

STATE OF FLORIDA  
COUNTY OF POLK

I HEREBY CERTIFY that on this day, before me, by means of  physical presence or  online notarization, an officer duly authorized to administer oaths and take acknowledgements, personally appeared Delaila S Tait, who is personally known to me to be the person described in and who executed the foregoing instrument, and who, being sworn by me, acknowledged before me the execution of same.

WITNESS, my hand and official seal in the County and State last aforesaid this 19th Day of February 2026. Barbara C Banks Notary Public

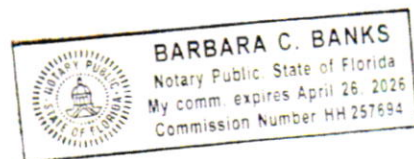

9589 0710 5270 3573 0473 25/

**U.S. Postal Service™**  
**CERTIFIED MAIL® RECEIPT**  
*Domestic Mail Only*

For delivery information, visit our website at [www.usps.com](http://www.usps.com)™.

Certified Mail Fee	\$ _____
Extra Services & Fees (check box, add fee as appropriate)	
<input type="checkbox"/> Return Receipt (hardcopy)	\$ _____
<input type="checkbox"/> Return Receipt (electronic)	\$ _____
<input type="checkbox"/> Certified Mail Restricted Delivery	\$ _____
<input type="checkbox"/> Adult Signature Required	\$ _____
<input type="checkbox"/> Adult Signature Restricted Delivery	\$ _____

Postmark  
Here

Timothy Bennett  
4104 Victoria BLVD  
Hampton VA 23669-4242

IN AND FOR THE CITY OF BARTOW, FLORIDA

CASE NO.: 26-0111

IN RE: 2015 Laurel St.

25-30-09-000000-033090

N 93.59 FT OF W 66 FT OF 1 AC OFF E END OF N1/2 OF S1/2 OF NE1/4 OF NW1/4 OF NW1/4 LESS N 20 FT FOR LAUREL ST, as recorded in the Public Records of Polk County, Florida

CITY OF BARTOW, a Florida municipal corporation,
Petitioner

v.

Timothy Bennett,
Respondent(s).

AFFIDAVIT OF SERVICE

I, Delaila S Tait, Code Enforcement Investigator, state as follows:

1. On 2/19/2026, I sent a copy of:

- Notice of Violation
Notice of Hearing
Notice of Hearing: Certification of Fines
Notice and Order of Demolition
Order Finding Violation
Order Imposing Fine

- Affidavit of: Non-Compliance Compliance
Order Authorizing Initiation of Demolition Process
Final Order Authorizing Demolition of Structure
Order on Request to Reduce Fine
Other:

Via Certified Mail First Class Mail Other:

to the property owner(s) at the address mailing address listed on the Polk County Property Appraiser's website:
2015 Laurel St E Bartow Fl 33830

2. On 02/19/2026, I posted a copy of the same at the above-described property; and

3. On 02/19/2026, I posted a copy of the same at City Hall.

4. Alternatively, I hand delivered a copy of the same to the property owner(s) on as
attested to by the following signature:

Delaila Tait
Code Compliance Investigator

STATE OF FLORIDA
COUNTY OF POLK

I HEREBY CERTIFY that on this day, before me, by means of physical presence or online notarization,
an officer duly authorized to administer oaths and take acknowledgements, personally
appeared Delaila S Tait, who is personally known to me to be the person described in and who executed
the foregoing instrument, and who, being sworn by me, acknowledged before me the execution of same.

WITNESS, my hand and official seal in the County and State last aforesaid this 19th Day of February,
2026. Barbara C. Banks Notary Public

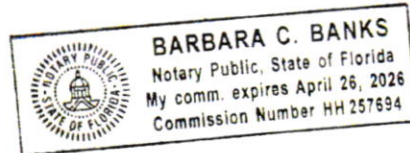

9589 0710 5270 3573 0472 71

**U.S. Postal Service™**  
**CERTIFIED MAIL® RECEIPT**  
*Domestic Mail Only*

For delivery information, visit our website at [www.usps.com](http://www.usps.com)®.

OFFICIAL USE

Certified Mail Fee	
\$	
Extra Services & Fees (check box, add fee as appropriate)	
<input type="checkbox"/> Return Receipt (hardcopy)	\$ _____
<input type="checkbox"/> Return Receipt (electronic)	\$ _____
<input type="checkbox"/> Certified Mail Restricted Delivery	\$ _____
<input type="checkbox"/> Adult Signature Required	\$ _____
<input type="checkbox"/> Adult Signature Restricted Delivery	\$ _____

Postmark  
Here

Timothy Bennett  
2015 Laurel St E  
Bartow FL 33830

**IN AND FOR THE CITY OF BARTOW, FLORIDA**

**CASE NO.: 26-0111**

**IN RE: 2015 Laurel St.**

**25-30-09-000000-033090**

**N 93.59 FT OF W 66 FT OF 1 AC OFF E END OF N1/2 OF S1/2 OF NE1/4 OF NW1/4 OF NW1/4 LESS N 20 FT FOR LAUREL ST, as recorded in the Public Records of Polk County, Florida**

**CITY OF BARTOW, a Florida municipal corporation,  
Petitioner**

**v.**

**Wanda Johnson,  
Respondent(s).**

**AFFIDAVIT OF SERVICE**

I, **Delaila S Tait**, Code Enforcement Investigator, state as follows:

1. On 2/19/2026, I sent a copy of:

- Notice of Violation
- Notice of Hearing
- Notice of Hearing: Certification of Fines
- Notice and Order of Demolition
- Order Finding Violation
- Order Imposing Fine

- Affidavit of:  Non-Compliance  Compliance
- Order Authorizing Initiation of Demolition Process
  - Final Order Authorizing Demolition of Structure
  - Order on Request to Reduce Fine
  - Other: \_\_\_\_\_

Via  Certified Mail  First Class Mail  Other: \_\_\_\_\_

to the property owner(s) at the address mailing address listed on the Polk County Property Appraiser's website:  
**4104 Vicotria Blvd Hampton VA 23669-4242**

2. On 02/19/2026, I posted a copy of the same at the above-described property; and

3. On 02/19/2026, I posted a copy of the same at City Hall.

4. Alternatively, I hand delivered a copy of the same to the property owner(s) on \_\_\_\_\_ as attested to by the following signature: \_\_\_\_\_

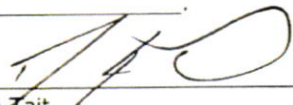
  
\_\_\_\_\_  
Delaila Tait  
Code Compliance Investigator

STATE OF FLORIDA  
COUNTY OF POLK

I HEREBY CERTIFY that on this day, before me, by means of  physical presence or  online notarization, an officer duly authorized to administer oaths and take acknowledgements, personally appeared Delaila S Tait, who is personally known to me to be the person described in and who executed the foregoing instrument, and who, being sworn by me, acknowledged before me the execution of same.

WITNESS my hand and official seal in the County and State last aforesaid this 19th Day of February, 2026. Barbara C. Banks Notary Public

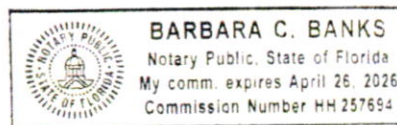

9589 0710 5270 3573 0473 18

**U.S. Postal Service™**  
**CERTIFIED MAIL® RECEIPT**  
*Domestic Mail Only*

For delivery information, visit our website at [www.usps.com](http://www.usps.com)®.

OFFICIAL USE

Certified Mail Fee	
\$	
Extra Services & Fees (check box, add fee as appropriate)	
<input type="checkbox"/> Return Receipt (hardcopy)	\$ _____
<input type="checkbox"/> Return Receipt (electronic)	\$ _____
<input type="checkbox"/> Certified Mail Restricted Delivery	\$ _____
<input type="checkbox"/> Adult Signature Required	\$ _____
<input type="checkbox"/> Adult Signature Restricted Delivery	\$ _____

Postmark  
Here

Wanda Johnson  
4104 Victoria BLVD  
Hampton VA 23669-4242

**IN AND FOR THE CITY OF BARTOW, FLORIDA**

**CASE NO.: 26-0111**

**IN RE: 2015 Laurel St.**

**25-30-09-000000-033090**

**N 93.59 FT OF W 66 FT OF 1 AC OFF E END OF N1/2 OF S1/2 OF NE1/4 OF NW1/4 OF NW1/4 LESS N 20 FT FOR LAUREL ST, as recorded in the Public Records of Polk County, Florida**

**CITY OF BARTOW, a Florida municipal corporation,  
Petitioner**

**v.**

**Sharlease Grandberry,  
Respondent(s).**

\_\_\_\_\_

**AFFIDAVIT OF SERVICE**

I, **Delaila S Tait**, Code Enforcement Investigator, state as follows:

1. On 2/19/2026, I sent a copy of:

- Notice of Violation
- Notice of Hearing
- Notice of Hearing: Certification of Fines
- Notice and Order of Demolition
- Order Finding Violation
- Order Imposing Fine

- Affidavit of:  Non-Compliance  Compliance
- Order Authorizing Initiation of Demolition Process
  - Final Order Authorizing Demolition of Structure
  - Order on Request to Reduce Fine
  - Other: \_\_\_\_\_

Via  Certified Mail  First Class Mail  Other: \_\_\_\_\_

to the property owner(s) at the address mailing address listed on the Polk County Property Appraiser's website:  
**4104 Vicotria Blvd Hampton VA 23669-4242**

2. On 02/19/2026, I posted a copy of the same at the above-described property; and

3. On 02/19/2026, I posted a copy of the same at City Hall.

4. Alternatively, I hand delivered a copy of the same to the property owner(s) on \_\_\_\_\_ as attested to by the following signature: \_\_\_\_\_

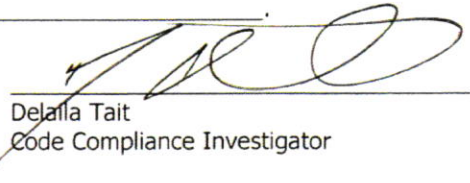
  
\_\_\_\_\_  
Delaila Tait  
Code Compliance Investigator

STATE OF FLORIDA  
COUNTY OF POLK

I HEREBY CERTIFY that on this day, before me, by means of  physical presence or  online notarization, an officer duly authorized to administer oaths and take acknowledgements, personally appeared Delaila S Tait, who is personally known to me to be the person described in and who executed the foregoing instrument, and who, being sworn by me, acknowledged before me the execution of same.

WITNESS, my hand and official seal in the County and State last aforesaid this 19th Day of February, 2026. Barbara C Banks Notary Public

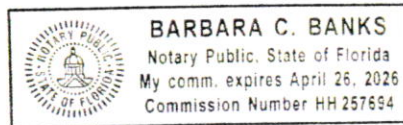

9589 0710 5270 3573 0473 01

**U.S. Postal Service™**  
**CERTIFIED MAIL® RECEIPT**  
*Domestic Mail Only*

For delivery information, visit our website at [www.usps.com](http://www.usps.com)®.

OFFICIAL USE

Certified Mail Fee	
\$	
Extra Services & Fees (check box, add fee as appropriate)	
<input type="checkbox"/> Return Receipt (hardcopy)	\$ _____
<input type="checkbox"/> Return Receipt (electronic)	\$ _____
<input type="checkbox"/> Certified Mail Restricted Delivery	\$ _____
<input type="checkbox"/> Adult Signature Required	\$ _____
<input type="checkbox"/> Adult Signature Restricted Delivery	\$ _____

Postmark  
Here

Postage

Sharlease Grandberry  
4104 Victoria BLVD  
Hampton VA 23669-4242

**IN AND FOR THE CITY OF BARTOW, FLORIDA**

**CASE NO.: 26-0111**

**IN RE: 2015 Laurel St.**

**25-30-09-000000-033090**

**N 93.59 FT OF W 66 FT OF 1 AC OFF E END OF N1/2 OF S1/2 OF NE1/4 OF NW1/4 OF NW1/4 LESS N 20 FT FOR LAUREL ST, as recorded in the Public Records of Polk County, Florida**

**CITY OF BARTOW, a Florida municipal corporation,  
Petitioner**

**v.**

**Sharlease Grandberry,  
Respondent(s).**

\_\_\_\_\_

**AFFIDAVIT OF SERVICE**

I, **Delaila S Tait**, Code Enforcement Investigator, state as follows:

1. On 2/19/2026, I sent a copy of:

- Notice of Violation
- Notice of Hearing
- Notice of Hearing: Certification of Fines
- Notice and Order of Demolition
- Order Finding Violation
- Order Imposing Fine

- Affidavit of:  Non-Compliance  Compliance
- Order Authorizing Initiation of Demolition Process
  - Final Order Authorizing Demolition of Structure
  - Order on Request to Reduce Fine
  - Other: \_\_\_\_\_

Via  Certified Mail  First Class Mail  Other: \_\_\_\_\_

to the property owner(s) at the address mailing address listed on the Polk County Property Appraiser's website:  
**2015 Laurel St E Bartow Fl 33830**

2. On 02/19/2026, I posted a copy of the same at the above-described property; and

3. On 02/19/2026, I posted a copy of the same at City Hall.

4. Alternatively, I hand delivered a copy of the same to the property owner(s) on \_\_\_\_\_ as attested to by the following signature: \_\_\_\_\_

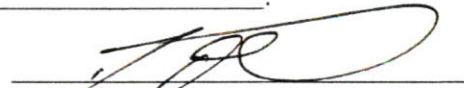
  
\_\_\_\_\_  
Delaila Tait  
Code Compliance Investigator

STATE OF FLORIDA  
COUNTY OF POLK

I HEREBY CERTIFY that on this day, before me, by means of  physical presence or  online notarization, an officer duly authorized to administer oaths and take acknowledgements, personally appeared Delaila S Tait, who is personally known to me to be the person described in and who executed the foregoing instrument, and who, being sworn by me, acknowledged before me the execution of same.

WITNESS, my hand and official seal in the County and State last aforesaid this 19th Day of February, 2026. Barbara C Banks Notary Public

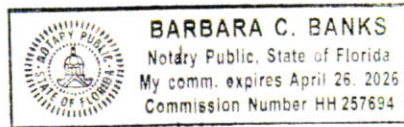

9589 0710 5270 3573 0472 95

**U.S. Postal Service™**  
**CERTIFIED MAIL® RECEIPT**  
*Domestic Mail Only*

For delivery information, visit our website at [www.usps.com](http://www.usps.com)™.

OFFICIAL USE

Certified Mail Fee	
\$	
Extra Services & Fees (check box, add fee as appropriate)	
<input type="checkbox"/> Return Receipt (hardcopy)	\$ _____
<input type="checkbox"/> Return Receipt (electronic)	\$ _____
<input type="checkbox"/> Certified Mail Restricted Delivery	\$ _____
<input type="checkbox"/> Adult Signature Required	\$ _____
<input type="checkbox"/> Adult Signature Restricted Delivery	\$ _____

Postmark  
Here

Sharlease Grandberry  
2015 Laurel St E  
Bartow FL 33830



**CITY OF BARTOW, FLORIDA  
NOTICE OF CODE VIOLATION  
CASE NO : 26-0111**

February 18, 2026

RADFORD FRANCES

4104 VICTORIA BLVD HAMPTON VA 23669-4242

Our records indicate that you are the owner of, mortgagee or have an interest in the following-described property within the City of Bartow, Florida:

**Real property located at LAUREL 2015 ST, Folio # 25300900000033090**

An inspection of this property by the Office of Code Compliance & Neighborhood Services discloses, and I have found and determined, that pursuant to the Minimum Property Maintenance Standards (MPMS) of the City of Bartow, as adopted by the Bartow Property Improvement Regulations Ordinance of 2012 ("BPIRO"), § 18-16, Code of Ordinances of the City of Bartow, Florida, a violation or violation(s) exist thereon so as to constitute a violation of:

**Code Book:** 2021 International Property Maintenance Code - **Code Title:** Section 304.7: Sub-Section: IPMC2021P2\_Ch03\_Sec304.7 Roofs and drainage. - **Code Section:** 304.7

**Ordinance:** The roof and flashing shall be sound, tight and not have defects that admit rain. Roof drainage shall be adequate to prevent dampness or deterioration in the walls or interior portion of the structure. Roof drains, gutters and downspouts shall be maintained in good repair and free from obstructions. Roof water shall not be discharged in a manner that creates a public nuisance.

**Conditions Found and Corrective Action Required:** **Structures roof is heavily damaged.**

**Repairs must be made to code.**

Continued violation will result in fees/fines.

---

**You are hereby notified** that the conditions described above **must be corrected by March 20, 2026** and must remain in compliance.

**It is your responsibility to contact Code Compliance and request a re-inspection.**

In the event you do not comply within the time specified in this Notice of Violation, pursuant to Chapter 38, Code of Ordinances of the City of Bartow, the City may:

1. Proceed to remedy this condition and the cost of the work, including advertising costs and other expenses, will be imposed as a non-ad valorem assessment and / or lien against all real and personal property owned by the above named pursuant to Chapter 162.09 (3) Florida State Statutes, and/or:
2. Refer the case to the City of Bartow's Code Enforcement Magistrate. If found in violation of City Code, the magistrate may assess a fine of up to \$250 per day for each day the property remains in non-compliance for first time offenses or up to \$500 per day for each day the property remains in non-compliance for repeat offenses, and/or:
3. Prosecute the owner, custodian, agent, lessee, trustee or occupant of the premises in county court pursuant to Article II, Division 4, of Chapter 29, Code of Ordinances of the City of Bartow.

If you have additional questions regarding your case, OR IF YOU NEED ASSISTANCE GAINING COMPLIANCE, you may contact the Office of Code Compliance & Neighborhood Services at (863) 534-

5034 Opt. 8 or via email at [codeenforcement@cityofbartow.net](mailto:codeenforcement@cityofbartow.net).

Delaila Tait  
Code Compliance Investigator  
Office of Code Compliance & Neighborhood Services  
450 N. Broadway Avenue  
Bartow, FL 33830

**IN AND FOR THE CITY OF BARTOW, FLORIDA**

**CASE NO.: 26-0111**

**IN RE: 2015 Laurel St.**

**25-30-09-000000-033090**

**N 93.59 FT OF W 66 FT OF 1 AC OFF E END OF N1/2 OF S1/2 OF NE1/4 OF NW1/4 OF NW1/4 LESS N 20 FT FOR LAUREL ST, as recorded in the Public Records of Polk County, Florida**

**CITY OF BARTOW, a Florida municipal corporation,  
Petitioner**

**v.**

**Frances Radford,  
Respondent(s).**

**AFFIDAVIT OF SERVICE**

I, **Delaila S Tait**, Code Enforcement Investigator, state as follows:

1. On 03/27/2026, I sent a copy of:

- Notice of Violation
- Notice of Hearing
- Notice of Hearing: Certification of Fines
- Notice and Order of Demolition
- Order Finding Violation
- Order Imposing Fine

- Affidavit of:  Non-Compliance  Compliance
- Order Authorizing Initiation of Demolition Process
  - Final Order Authorizing Demolition of Structure
  - Order on Request to Reduce Fine
  - Other: \_\_\_\_\_

Via  Certified Mail  First Class Mail  Other: \_\_\_\_\_

to the property owner(s) at the address mailing address listed on the Polk County Property Appraiser's website:  
**4104 Vicotria Blvd Hampton VA 23669-4242**

2. On 03/27/2026, I posted a copy of the same at the above-described property; and

3. On 03/27/2026, I posted a copy of the same at City Hall.

4. Alternatively, I hand delivered a copy of the same to the property owner(s) on \_\_\_\_\_ as attested to by the following signature: \_\_\_\_\_

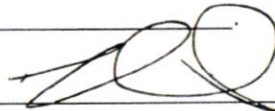
  
\_\_\_\_\_  
Delaila Tait  
Code Compliance Investigator

STATE OF FLORIDA  
COUNTY OF POLK

I HEREBY CERTIFY that on this day, before me, by means of  physical presence or  online notarization, an officer duly authorized to administer oaths and take acknowledgements, personally appeared Delaila S Tait, who is personally known to me to be the person described in and who executed the foregoing instrument, and who, being sworn by me, acknowledged before me the execution of same.

WITNESS, my hand and official seal in the County and State last aforesaid this 27th Day of March, 2026. Barbara C Banks Notary Public

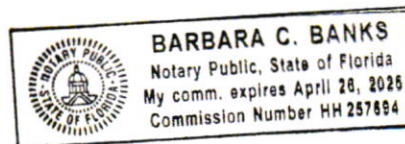

9589 0710 5270 3573 0478 06

**U.S. Postal Service™**  
**CERTIFIED MAIL® RECEIPT**  
*Domestic Mail Only*

For delivery information, visit our website at [www.usps.com](http://www.usps.com)®.

0710 5270 3573 0478 06

Certified Mail Fee	
\$	
Extra Services & Fees (check box, add fee as appropriate)	
<input type="checkbox"/> Return Receipt (hardcopy)	\$ _____
<input type="checkbox"/> Return Receipt (electronic)	\$ _____
<input type="checkbox"/> Certified Mail Restricted Delivery	\$ _____
<input type="checkbox"/> Adult Signature Required	\$ _____
<input type="checkbox"/> Adult Signature Restricted Delivery	\$ _____

Postmark  
Here

Frances Radford  
4104 Victoria Blvd  
Hampton VA 23669-4242

PS Form 3800, January 2023 PSN 7530-02-000-9047 See Reverse for Instructions

**IN AND FOR THE CITY OF BARTOW, FLORIDA**

**CASE NO.: 26-0111**

**IN RE: 2015 Laurel St.**

**25-30-09-000000-033090**

**N 93.59 FT OF W 66 FT OF 1 AC OFF E END OF N1/2 OF S1/2 OF NE1/4 OF NW1/4 OF NW1/4 LESS N 20 FT FOR LAUREL ST, as recorded in the Public Records of Polk County, Florida**

**CITY OF BARTOW, a Florida municipal corporation,  
Petitioner**

**v.**

**Yvonne Washington,  
Respondent(s).**

**AFFIDAVIT OF SERVICE**

I, **Delaila S Tait**, Code Enforcement Investigator, state as follows:

1. On 03/27/2026, I sent a copy of:

- Notice of Violation
- Notice of Hearing
- Notice of Hearing: Certification of Fines
- Notice and Order of Demolition
- Order Finding Violation
- Order Imposing Fine

- Affidavit of:  Non-Compliance  Compliance
- Order Authorizing Initiation of Demolition Process
  - Final Order Authorizing Demolition of Structure
  - Order on Request to Reduce Fine
  - Other: \_\_\_\_\_

Via  Certified Mail  First Class Mail  Other: \_\_\_\_\_

to the property owner(s) at the address mailing address listed on the Polk County Property Appraiser's website:  
**4104 Vicotria Blvd Hampton VA 23669-4242**

2. On 03/27/2026, I posted a copy of the same at the above-described property; and

3. On 03/27/2026, I posted a copy of the same at City Hall.

4. Alternatively, I hand delivered a copy of the same to the property owner(s) on \_\_\_\_\_ as attested to by the following signature: \_\_\_\_\_

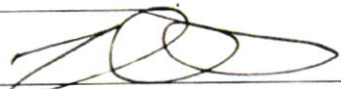
  
\_\_\_\_\_  
Delaila Tait  
Code Compliance Investigator

STATE OF FLORIDA  
COUNTY OF POLK

I HEREBY CERTIFY that on this day, before me, by means of  physical presence or  online notarization, an officer duly authorized to administer oaths and take acknowledgements, personally appeared Delaila S Tait, who is personally known to me to be the person described in and who executed the foregoing instrument, and who, being sworn by me, acknowledged before me the execution of same.

WITNESS, my hand and official seal in the County and State last aforesaid this 27th Day of March, 2026. Barbara C Banks Notary Public

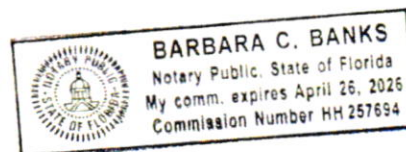

9589 0710 5270 3573 0477 90

**U.S. Postal Service™**  
**CERTIFIED MAIL® RECEIPT**  
*Domestic Mail Only*

For delivery information, visit our website at [www.usps.com](http://www.usps.com)®.

Certified Mail Fee	
\$	
Extra Services & Fees (check box, add fee as appropriate)	
<input type="checkbox"/> Return Receipt (hardcopy)	\$ _____
<input type="checkbox"/> Return Receipt (electronic)	\$ _____
<input type="checkbox"/> Certified Mail Restricted Delivery	\$ _____
<input type="checkbox"/> Adult Signature Required	\$ _____
<input type="checkbox"/> Adult Signature Restricted Delivery	\$ _____

Postmark  
Here

Phetara  
**Yvonne Washington**  
**4104 Victoria Blvd**  
**Hampton VA 23669-4242**

PS Form 3800, January 2023 PSN 7530-02-000-9047 See Reverse for Instructions

**IN AND FOR THE CITY OF BARTOW, FLORIDA**

**CASE NO.: 26-0111**

**IN RE: 2015 Laurel St.**

**25-30-09-000000-033090**

**N 93.59 FT OF W 66 FT OF 1 AC OFF E END OF N1/2 OF S1/2 OF NE1/4 OF NW1/4 OF NW1/4 LESS N 20 FT FOR LAUREL ST, as recorded in the Public Records of Polk County, Florida**

**CITY OF BARTOW, a Florida municipal corporation,  
Petitioner**

v.

**Marion Motley,  
Respondent(s).**

**AFFIDAVIT OF SERVICE**

I, **Delaila S Tait**, Code Enforcement Investigator, state as follows:

1. On 03/27/2026, I sent a copy of:

- Notice of Violation
- Notice of Hearing
- Notice of Hearing: Certification of Fines
- Notice and Order of Demolition
- Order Finding Violation
- Order Imposing Fine

- Affidavit of:  Non-Compliance  Compliance
- Order Authorizing Initiation of Demolition Process
  - Final Order Authorizing Demolition of Structure
  - Order on Request to Reduce Fine
  - Other: \_\_\_\_\_

Via  Certified Mail  First Class Mail  Other: \_\_\_\_\_

to the property owner(s) at the address mailing address listed on the Polk County Property Appraiser's website:  
**4104 Vicotria Blvd Hampton VA 23669-4242**

2. On 03/27/2026, I posted a copy of the same at the above-described property; and

3. On 03/27/2026, I posted a copy of the same at City Hall.

4. Alternatively, I hand delivered a copy of the same to the property owner(s) on \_\_\_\_\_ as attested to by the following signature: \_\_\_\_\_

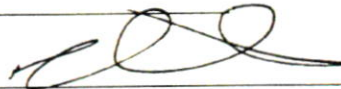
  
\_\_\_\_\_  
Delaila Tait  
Code Compliance Investigator

STATE OF FLORIDA  
COUNTY OF POLK

I HEREBY CERTIFY that on this day, before me, by means of  physical presence or  online notarization, an officer duly authorized to administer oaths and take acknowledgements, personally appeared Delaila S Tait, who is personally known to me to be the person described in and who executed the foregoing instrument, and who, being sworn by me, acknowledged before me the execution of same.

WITNESS, my hand and official seal in the County and State last aforesaid this 27th Day of March, 2026. Barbara C Banks Notary Public

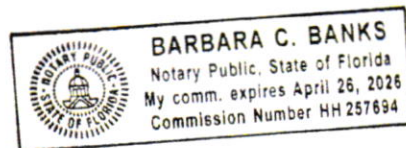

9589 0710 5270 3573 0477 83

**U.S. Postal Service™**  
**CERTIFIED MAIL® RECEIPT**  
*Domestic Mail Only*

For delivery information, visit our website at [www.usps.com](http://www.usps.com)®.

Certified Mail Fee

\$

Extra Services & Fees (check box, add fee as appropriate)

- Return Receipt (hardcopy) \$ \_\_\_\_\_
- Return Receipt (electronic) \$ \_\_\_\_\_
- Certified Mail Restricted Delivery \$ \_\_\_\_\_
- Adult Signature Required \$ \_\_\_\_\_
- Adult Signature Restricted Delivery \$ \_\_\_\_\_

Postmark  
Here

**Marion Motley**  
**4104 Victoria Blvd**  
**Hampton VA 23669-4242**

PS Form 3800, January 2023 PSN 7530-02-000-9047 See Reverse for Instructions

**IN AND FOR THE CITY OF BARTOW, FLORIDA**

**CASE NO.: 26-0111**

**IN RE: 2015 Laurel St.**

**25-30-09-000000-033090**

**N 93.59 FT OF W 66 FT OF 1 AC OFF E END OF N1/2 OF S1/2 OF NE1/4 OF NW1/4 OF NW1/4 LESS N 20 FT FOR LAUREL ST, as recorded in the Public Records of Polk County, Florida**

**CITY OF BARTOW, a Florida municipal corporation,  
Petitioner**

**v.**

**Tamara Bostic,  
Respondent(s).**

**AFFIDAVIT OF SERVICE**

I, **Delaila S Tait**, Code Enforcement Investigator, state as follows:

1. On 03/27/2026, I sent a copy of:

- Notice of Violation
- Notice of Hearing
- Notice of Hearing: Certification of Fines
- Notice and Order of Demolition
- Order Finding Violation
- Order Imposing Fine

- Affidavit of:  Non-Compliance  Compliance
- Order Authorizing Initiation of Demolition Process
  - Final Order Authorizing Demolition of Structure
  - Order on Request to Reduce Fine
  - Other: \_\_\_\_\_

Via  Certified Mail  First Class Mail  Other: \_\_\_\_\_

to the property owner(s) at the address mailing address listed on the Polk County Property Appraiser's website:  
**4104 Vicotria Blvd Hampton VA 23669-4242**

- 2. On 03/27/2026, I posted a copy of the same at the above-described property; and
- 3. On 03/27/2026, I posted a copy of the same at City Hall.
- 4. Alternatively, I hand delivered a copy of the same to the property owner(s) on \_\_\_\_\_ as attested to by the following signature: \_\_\_\_\_

  
\_\_\_\_\_  
Delaila Tait  
Code Compliance Investigator

STATE OF FLORIDA  
COUNTY OF POLK

I HEREBY CERTIFY that on this day, before me, by means of  physical presence or \_\_\_ online notarization, an officer duly authorized to administer oaths and take acknowledgements, personally appeared Delaila S Tait, who is personally known to me to be the person described in and who executed the foregoing instrument, and who, being sworn by me, acknowledged before me the execution of same.

WITNESS, my hand and official seal in the County and State last aforesaid this 27th Day of March, 2026. Barbara C Banks Notary Public

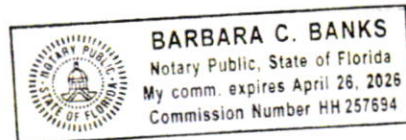

9589 0710 5270 3573 0477 76

**U.S. Postal Service™**  
**CERTIFIED MAIL® RECEIPT**  
*Domestic Mail Only*

For delivery information, visit our website at [www.usps.com](http://www.usps.com)®.

Certified Mail Fee	
\$	_____
Extra Services & Fees (check box, add fee as appropriate)	
<input type="checkbox"/> Return Receipt (hardcopy)	\$ _____
<input type="checkbox"/> Return Receipt (electronic)	\$ _____
<input type="checkbox"/> Certified Mail Restricted Delivery	\$ _____
<input type="checkbox"/> Adult Signature Required	\$ _____
<input type="checkbox"/> Adult Signature Restricted Delivery	\$ _____

Postmark  
Here

Tamara Bostic  
4104 Victoria Blvd  
Hampton VA 23669-4242

PS Form 3800, January 2023 PSN 7530-02-000-9047 See Reverse for Instructions

**IN AND FOR THE CITY OF BARTOW, FLORIDA**

**CASE NO.: 26-0111**

**IN RE: 2015 Laurel St.**

**25-30-09-000000-033090**

**N 93.59 FT OF W 66 FT OF 1 AC OFF E END OF N1/2 OF S1/2 OF NE1/4 OF NW1/4 OF NW1/4 LESS N 20 FT FOR LAUREL ST, as recorded in the Public Records of Polk County, Florida**

**CITY OF BARTOW, a Florida municipal corporation,  
Petitioner**

v.

**Timothy Bennett,  
Respondent(s).**

**AFFIDAVIT OF SERVICE**

I, **Delaila S Tait**, Code Enforcement Investigator, state as follows:

1. On 03/27/2026, I sent a copy of:

- Notice of Violation
- Notice of Hearing
- Notice of Hearing: Certification of Fines
- Notice and Order of Demolition
- Order Finding Violation
- Order Imposing Fine

- Affidavit of:  Non-Compliance  Compliance
- Order Authorizing Initiation of Demolition Process
  - Final Order Authorizing Demolition of Structure
  - Order on Request to Reduce Fine
  - Other: \_\_\_\_\_

Via  Certified Mail  First Class Mail  Other: \_\_\_\_\_

to the property owner(s) at the address mailing address listed on the Polk County Property Appraiser's website:  
**4104 Vicotria Blvd Hampton VA 23669-4242**

- 2. On 03/27/2026, I posted a copy of the same at the above-described property; and
- 3. On 03/27/2026, I posted a copy of the same at City Hall.
- 4. Alternatively, I hand delivered a copy of the same to the property owner(s) on \_\_\_\_\_ as attested to by the following signature: \_\_\_\_\_

  
\_\_\_\_\_  
Delaila Tait  
Code Compliance Investigator

STATE OF FLORIDA  
COUNTY OF POLK

I HEREBY CERTIFY that on this day, before me, by means of  physical presence or  online notarization, an officer duly authorized to administer oaths and take acknowledgements, personally appeared Delaila S Tait, who is personally known to me to be the person described in and who executed the foregoing instrument, and who, being sworn by me, acknowledged before me the execution of same.

WITNESS, my hand and official seal in the County and State last aforesaid this 17th Day of March, 2026.  
Barbara C. Banks Notary Public

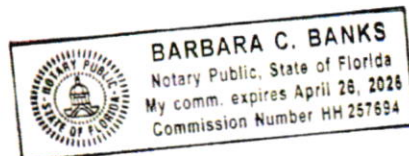

9589 0710 5270 3573 0477 69

**U.S. Postal Service™**  
**CERTIFIED MAIL® RECEIPT**  
*Domestic Mail Only*

For delivery information, visit our website at [www.usps.com](http://www.usps.com)®.

Certified Mail Fee	\$	
Extra Services & Fees (check box, add fee as appropriate)		
<input type="checkbox"/> Return Receipt (hardcopy)	\$	
<input type="checkbox"/> Return Receipt (electronic)	\$	
<input type="checkbox"/> Certified Mail Restricted Delivery	\$	
<input type="checkbox"/> Adult Signature Required	\$	
<input type="checkbox"/> Adult Signature Restricted Delivery	\$	

Postmark  
Here

Postage

**Timothy Bennett**  
**4104 Victoria Blvd**  
**Hampton VA 23669-4242**

**IN AND FOR THE CITY OF BARTOW, FLORIDA**

**CASE NO.: 26-0111**

**IN RE: 2015 Laurel St.**

**25-30-09-000000-033090**

**N 93.59 FT OF W 66 FT OF 1 AC OFF E END OF N1/2 OF S1/2 OF NE1/4 OF NW1/4 OF NW1/4 LESS N 20 FT FOR LAUREL ST, as recorded in the Public Records of Polk County, Florida**

**CITY OF BARTOW, a Florida municipal corporation,  
Petitioner**

**v.**

**Raginald Washington,  
Respondent(s).**

**AFFIDAVIT OF SERVICE**

I, **Delaila S Tait**, Code Enforcement Investigator, state as follows:

1. On 03/27/2026, I sent a copy of:

- Notice of Violation
- Notice of Hearing
- Notice of Hearing: Certification of Fines
- Notice and Order of Demolition
- Order Finding Violation
- Order Imposing Fine

- Affidavit of:  Non-Compliance  Compliance
- Order Authorizing Initiation of Demolition Process
  - Final Order Authorizing Demolition of Structure
  - Order on Request to Reduce Fine
  - Other: \_\_\_\_\_

Via  Certified Mail  First Class Mail  Other: \_\_\_\_\_

to the property owner(s) at the address mailing address listed on the Polk County Property Appraiser's website:  
**4104 Vicotria Blvd Hampton VA 23669-4242**

2. On 03/27/2026, I posted a copy of the same at the above-described property; and

3. On 03/27/2026, I posted a copy of the same at City Hall.

4. Alternatively, I hand delivered a copy of the same to the property owner(s) on \_\_\_\_\_ as attested to by the following signature: \_\_\_\_\_

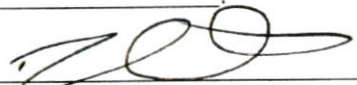
  
\_\_\_\_\_  
Delaila Tait  
Code Compliance Investigator

STATE OF FLORIDA  
COUNTY OF POLK

I HEREBY CERTIFY that on this day, before me, by means of  physical presence or  online notarization, an officer duly authorized to administer oaths and take acknowledgements, personally appeared Delaila S Tait, who is personally known to me to be the person described in and who executed the foregoing instrument, and who, being sworn by me, acknowledged before me the execution of same.

WITNESS, my hand and official seal in the County and State last aforesaid this 27th Day of March, 2026. Barbara C Banks Notary Public

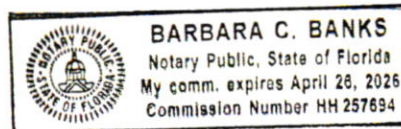

9589 0710 5270 3573 0477 52

**U.S. Postal Service™**  
**CERTIFIED MAIL® RECEIPT**  
*Domestic Mail Only*

For delivery information, visit our website at [www.usps.com](http://www.usps.com)®.

OFFICIAL USE

Certified Mail Fee	
\$	
Extra Services & Fees (check box, add fee as appropriate)	
<input type="checkbox"/> Return Receipt (hardcopy)	\$ _____
<input type="checkbox"/> Return Receipt (electronic)	\$ _____
<input type="checkbox"/> Certified Mail Restricted Delivery	\$ _____
<input type="checkbox"/> Adult Signature Required	\$ _____
<input type="checkbox"/> Adult Signature Restricted Delivery	\$ _____

Postmark  
Here

Postage  
**Reginald Washington**  
**4104 Victoria Blvd**  
**Hampton VA 23669-4242**

PS Form 3800, January 2023 PSN 7530-02-000-9047 See Reverse for Instructions

**IN AND FOR THE CITY OF BARTOW, FLORIDA**

**CASE NO.: 26-0111**

**IN RE: 2015 Laurel St.**

**25-30-09-000000-033090**

**N 93.59 FT OF W 66 FT OF 1 AC OFF E END OF N1/2 OF S1/2 OF NE1/4 OF NW1/4 OF NW1/4 LESS N 20 FT FOR LAUREL ST, as recorded in the Public Records of Polk County, Florida**

**CITY OF BARTOW, a Florida municipal corporation,  
Petitioner**

**v.**

**Wanda Johnson,  
Respondent(s).**

**AFFIDAVIT OF SERVICE**

I, **Delaila S Tait**, Code Enforcement Investigator, state as follows:

1. On 03/27/2026, I sent a copy of:

- Notice of Violation
- Notice of Hearing
- Notice of Hearing: Certification of Fines
- Notice and Order of Demolition
- Order Finding Violation
- Order Imposing Fine

- Affidavit of:  Non-Compliance  Compliance
- Order Authorizing Initiation of Demolition Process
  - Final Order Authorizing Demolition of Structure
  - Order on Request to Reduce Fine
  - Other: \_\_\_\_\_

Via  Certified Mail  First Class Mail  Other: \_\_\_\_\_

to the property owner(s) at the address mailing address listed on the Polk County Property Appraiser's website:  
**4104 Vicotria Blvd Hampton VA 23669-4242**

2. On 03/27/2026, I posted a copy of the same at the above-described property; and

3. On 03/27/2026, I posted a copy of the same at City Hall.

4. Alternatively, I hand delivered a copy of the same to the property owner(s) on \_\_\_\_\_ as attested to by the following signature: \_\_\_\_\_

  
\_\_\_\_\_  
Delaila Tait  
Code Compliance Investigator

STATE OF FLORIDA  
COUNTY OF POLK

I HEREBY CERTIFY that on this day, before me, by means of  physical presence or  online notarization, an officer duly authorized to administer oaths and take acknowledgements, personally appeared Delaila S Tait, who is personally known to me to be the person described in and who executed the foregoing instrument, and who, being sworn by me, acknowledged before me the execution of same.

WITNESS, my hand and official seal in the County and State last aforesaid this 27th Day of March, 2026. Barbara C Banks Notary Public

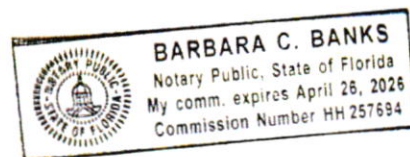

9589 0710 5270 3573 0477 45

**U.S. Postal Service™**  
**CERTIFIED MAIL® RECEIPT**  
*Domestic Mail Only*

For delivery information, visit our website at [www.usps.com](http://www.usps.com)™.

Certified Mail Fee	
\$	
Extra Services & Fees (check box, add fee as appropriate)	
<input type="checkbox"/> Return Receipt (hardcopy)	\$ _____
<input type="checkbox"/> Return Receipt (electronic)	\$ _____
<input type="checkbox"/> Certified Mail Restricted Delivery	\$ _____
<input type="checkbox"/> Adult Signature Required	\$ _____
<input type="checkbox"/> Adult Signature Restricted Delivery	\$ _____

Postmark  
Here

Wanda Johnson  
4104 Victoria Blvd  
Hampton VA 23669-4242

PS Form 3800, January 2023 PSN 7530-02-000-9047 See Reverse for Instructions

**IN AND FOR THE CITY OF BARTOW, FLORIDA**

**CASE NO.: 26-0111**

**IN RE: 2015 Laurel St.**

**25-30-09-000000-033090**

**N 93.59 FT OF W 66 FT OF 1 AC OFF E END OF N1/2 OF S1/2 OF NE1/4 OF NW1/4 OF NW1/4 LESS N 20 FT FOR LAUREL ST, as recorded in the Public Records of Polk County, Florida**

**CITY OF BARTOW, a Florida municipal corporation,  
Petitioner**

**v.**

**Fredrick Washington,  
Respondent(s).**

**AFFIDAVIT OF SERVICE**

I, **Delaila S Tait**, Code Enforcement Investigator, state as follows:

1. On 03/27/2026, I sent a copy of:

- Notice of Violation
- Notice of Hearing
- Notice of Hearing: Certification of Fines
- Notice and Order of Demolition
- Order Finding Violation
- Order Imposing Fine

- Affidavit of:  Non-Compliance  Compliance
- Order Authorizing Initiation of Demolition Process
  - Final Order Authorizing Demolition of Structure
  - Order on Request to Reduce Fine
  - Other: \_\_\_\_\_

Via  Certified Mail  First Class Mail  Other: \_\_\_\_\_

to the property owner(s) at the address mailing address listed on the Polk County Property Appraiser's website:  
**4104 Vicotria Blvd Hampton VA 23669-4242**

2. On 03/27/2026, I posted a copy of the same at the above-described property; and

3. On 03/27/2026, I posted a copy of the same at City Hall.

4. Alternatively, I hand delivered a copy of the same to the property owner(s) on \_\_\_\_\_ as attested to by the following signature: \_\_\_\_\_

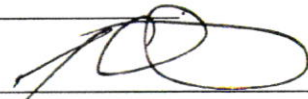
  
\_\_\_\_\_  
Delaila Tait  
Code Compliance Investigator

STATE OF FLORIDA  
COUNTY OF POLK

I HEREBY CERTIFY that on this day, before me, by means of  physical presence or  online notarization, an officer duly authorized to administer oaths and take acknowledgements, personally appeared Delaila S Tait, who is personally known to me to be the person described in and who executed the foregoing instrument, and who, being sworn by me, acknowledged before me the execution of same.

WITNESS, my hand and official seal in the County and State last aforesaid this 27th Day of March, 2026. Barbara C Banks Notary Public

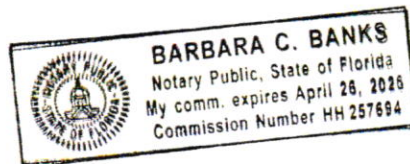

9589 0710 5270 3573 0477 38

**U.S. Postal Service™**  
**CERTIFIED MAIL® RECEIPT**  
*Domestic Mail Only*

For delivery information, visit our website at [www.usps.com](http://www.usps.com)™.

Certified Mail Fee	
\$	
Extra Services & Fees (check box, add fee as appropriate)	
<input type="checkbox"/> Return Receipt (hardcopy)	\$ _____
<input type="checkbox"/> Return Receipt (electronic)	\$ _____
<input type="checkbox"/> Certified Mail Restricted Delivery	\$ _____
<input type="checkbox"/> Adult Signature Required	\$ _____
<input type="checkbox"/> Adult Signature Restricted Delivery	\$ _____
Postage	

Postmark  
Here

**Fredrick Washington**  
**4104 Victoria Blvd**  
**Hampton VA 23669-4242**

See Reverse for Instructions

**IN AND FOR THE CITY OF BARTOW, FLORIDA**

**CASE NO.: 26-0111**

**IN RE: 2015 Laurel St.**

**25-30-09-000000-033090**

**N 93.59 FT OF W 66 FT OF 1 AC OFF E END OF N1/2 OF S1/2 OF NE1/4 OF NW1/4 OF NW1/4 LESS N 20 FT FOR LAUREL ST, as recorded in the Public Records of Polk County, Florida**

**CITY OF BARTOW, a Florida municipal corporation,  
Petitioner**

**v.**

**Sharlease Grandberry,  
Respondent(s).**

**AFFIDAVIT OF SERVICE**

I, **Delaila S Tait**, Code Enforcement Investigator, state as follows:

1. On 03/27/2026, I sent a copy of:

- Notice of Violation
- Notice of Hearing
- Notice of Hearing: Certification of Fines
- Notice and Order of Demolition
- Order Finding Violation
- Order Imposing Fine

- Affidavit of:  Non-Compliance  Compliance
- Order Authorizing Initiation of Demolition Process
  - Final Order Authorizing Demolition of Structure
  - Order on Request to Reduce Fine
  - Other: \_\_\_\_\_

Via  Certified Mail  First Class Mail  Other: \_\_\_\_\_

to the property owner(s) at the address mailing address listed on the Polk County Property Appraiser's website:  
**4104 Vicotria Blvd Hampton VA 23669-4242**

- 2. On 03/27/2026, I posted a copy of the same at the above-described property; and
- 3. On 03/27/2026, I posted a copy of the same at City Hall.
- 4. Alternatively, I hand delivered a copy of the same to the property owner(s) on \_\_\_\_\_ as attested to by the following signature: \_\_\_\_\_

  
 \_\_\_\_\_  
 Delaila Tait  
 Code Compliance Investigator

STATE OF FLORIDA  
COUNTY OF POLK

I HEREBY CERTIFY that on this day, before me, by means of  physical presence or  online notarization, an officer duly authorized to administer oaths and take acknowledgements, personally appeared Delaila S Tait, who is personally known to me to be the person described in and who executed the foregoing instrument, and who, being sworn by me, acknowledged before me the execution of same.

WITNESS, my hand and official seal in the County and State last aforesaid this 27th Day of March, 2026.  
\_\_\_\_\_  
Notary Public

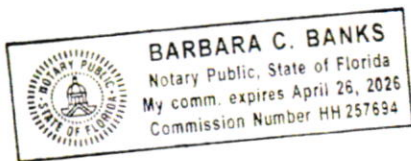

9589 0710 5270 3573 0477 21

**U.S. Postal Service™**  
**CERTIFIED MAIL® RECEIPT**  
*Domestic Mail Only*

For delivery information, visit our website at [www.usps.com](http://www.usps.com)®.

Certified Mail Fee	
\$	_____
Extra Services & Fees (check box, add fee as appropriate)	
<input type="checkbox"/> Return Receipt (hardcopy)	\$ _____
<input type="checkbox"/> Return Receipt (electronic)	\$ _____
<input type="checkbox"/> Certified Mail Restricted Delivery	\$ _____
<input type="checkbox"/> Adult Signature Required	\$ _____
<input type="checkbox"/> Adult Signature Restricted Delivery	\$ _____

Postmark  
Here

Postage

**Sharlease Grandberry**  
**4104 Victoria Blvd**  
**Hampton VA 23669-4242**

PS Form 3800, January 2023 PSN 7530-02-000-9047 See Reverse for Instructions

**IN AND FOR THE CITY OF BARTOW, FLORIDA**

**CASE NO.: 26-0111**

**IN RE: 2015 Laurel St.**

**25-30-09-000000-033090**

**N 93.59 FT OF W 66 FT OF 1 AC OFF E END OF N1/2 OF S1/2 OF NE1/4 OF NW1/4 OF NW1/4 LESS N 20 FT FOR LAUREL ST, as recorded in the Public Records of Polk County, Florida**

**CITY OF BARTOW, a Florida municipal corporation,  
Petitioner**

**v.**

**Andrea Washington,  
Respondent(s).**

**AFFIDAVIT OF SERVICE**

I, **Delaila S Tait**, Code Enforcement Investigator, state as follows:

1. On 03/27/2026, I sent a copy of:

- Notice of Violation
- Notice of Hearing
- Notice of Hearing: Certification of Fines
- Notice and Order of Demolition
- Order Finding Violation
- Order Imposing Fine

- Affidavit of:  Non-Compliance  Compliance
- Order Authorizing Initiation of Demolition Process
  - Final Order Authorizing Demolition of Structure
  - Order on Request to Reduce Fine
  - Other: \_\_\_\_\_

Via  Certified Mail  First Class Mail  Other: \_\_\_\_\_

to the property owner(s) at the address mailing address listed on the Polk County Property Appraiser's website:  
**4104 Vicotria Blvd Hampton VA 23669-4242**

2. On 03/27/2026, I posted a copy of the same at the above-described property; and

3. On 03/27/2026, I posted a copy of the same at City Hall.

4. Alternatively, I hand delivered a copy of the same to the property owner(s) on \_\_\_\_\_ as attested to by the following signature: \_\_\_\_\_

  
\_\_\_\_\_  
Delaila Tait  
Code Compliance Investigator

STATE OF FLORIDA  
COUNTY OF POLK

I HEREBY CERTIFY that on this day, before me, by means of  physical presence or  online notarization, an officer duly authorized to administer oaths and take acknowledgements, personally appeared Delaila S Tait, who is personally known to me to be the person described in and who executed the foregoing instrument, and who, being sworn by me, acknowledged before me the execution of same.

WITNESS, my hand and official seal in the County and State last aforesaid this 27th Day of March, 2026. Barbara C Banks Notary Public

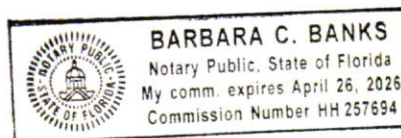

9589 0710 5270 3573 0477 14

**U.S. Postal Service™**  
**CERTIFIED MAIL® RECEIPT**  
*Domestic Mail Only*

For delivery information, visit our website at [www.usps.com](http://www.usps.com)®.

OFFICIAL USE

Certified Mail Fee	\$
Extra Services & Fees (check box, add fee as appropriate)	
<input type="checkbox"/> Return Receipt (hardcopy)	\$ _____
<input type="checkbox"/> Return Receipt (electronic)	\$ _____
<input type="checkbox"/> Certified Mail Restricted Delivery	\$ _____
<input type="checkbox"/> Adult Signature Required	\$ _____
<input type="checkbox"/> Adult Signature Restricted Delivery	\$ _____

Postmark  
Here

**Andrea Washington**  
**4104 Victoria Blvd**  
**Hampton VA 23669-4242**

PS Form 3800, January 2023 PSN 7530-02-000-9047 See Reverse for Instructions

**IN AND FOR THE CITY OF BARTOW, FLORIDA**

**CASE NO.: 26-0111**

**IN RE: 2015 Laurel St.**

**25-30-09-000000-033090**

**N 93.59 FT OF W 66 FT OF 1 AC OFF E END OF N1/2 OF S1/2 OF NE1/4 OF NW1/4 OF NW1/4 LESS N 20 FT FOR LAUREL ST, as recorded in the Public Records of Polk County, Florida**

**CITY OF BARTOW, a Florida municipal corporation,  
Petitioner**

**v.**

**Ronald Washington,  
Respondent(s).**

**AFFIDAVIT OF SERVICE**

I, **Delaila S Tait**, Code Enforcement Investigator, state as follows:

1. On 03/27/2026, I sent a copy of:

- Notice of Violation
- Notice of Hearing
- Notice of Hearing: Certification of Fines
- Notice and Order of Demolition
- Order Finding Violation
- Order Imposing Fine

- Affidavit of:  Non-Compliance  Compliance
- Order Authorizing Initiation of Demolition Process
  - Final Order Authorizing Demolition of Structure
  - Order on Request to Reduce Fine
  - Other: \_\_\_\_\_

Via  Certified Mail  First Class Mail  Other: \_\_\_\_\_

to the property owner(s) at the address mailing address listed on the Polk County Property Appraiser's website:  
**4104 Vicotria Blvd Hampton VA 23669-4242**

2. On 03/27/2026, I posted a copy of the same at the above-described property; and

3. On 03/27/2026, I posted a copy of the same at City Hall.

4. Alternatively, I hand delivered a copy of the same to the property owner(s) on \_\_\_\_\_ as attested to by the following signature: \_\_\_\_\_

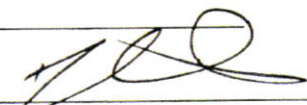
  
\_\_\_\_\_  
Delaila Tait  
Code Compliance Investigator

STATE OF FLORIDA  
COUNTY OF POLK

I HEREBY CERTIFY that on this day, before me, by means of  physical presence or \_\_\_ online notarization, an officer duly authorized to administer oaths and take acknowledgements, personally appeared Delaila S Tait, who is personally known to me to be the person described in and who executed the foregoing instrument, and who, being sworn by me, acknowledged before me the execution of same.

WITNESS, my hand and official seal in the County and State last aforesaid this 27th Day of March, 2026. Barbara C Banks Notary Public

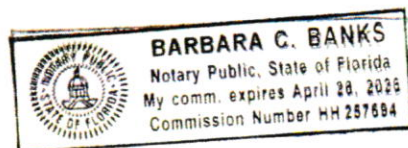

9589 0710 5270 3573 0477 07

**U.S. Postal Service™**  
**CERTIFIED MAIL® RECEIPT**  
*Domestic Mail Only*

For delivery information, visit our website at [www.usps.com](http://www.usps.com)®.

Certified Mail Fee	
\$	
Extra Services & Fees (check box, add fee as appropriate)	
<input type="checkbox"/> Return Receipt (hardcopy)	\$ _____
<input type="checkbox"/> Return Receipt (electronic)	\$ _____
<input type="checkbox"/> Certified Mail Restricted Delivery	\$ _____
<input type="checkbox"/> Adult Signature Required	\$ _____
<input type="checkbox"/> Adult Signature Restricted Delivery	\$ _____

Postmark  
Here

Ronald Washington  
4104 Victoria Blvd  
Hampton VA 23669-4242

**IN AND FOR THE CITY OF BARTOW, FLORIDA**

**CASE NO.: 26-0111**

**IN RE: 2015 Laurel St.**

**25-30-09-000000-033090**

**N 93.59 FT OF W 66 FT OF 1 AC OFF E END OF N1/2 OF S1/2 OF NE1/4 OF NW1/4 OF NW1/4 LESS N 20 FT FOR LAUREL ST, as recorded in the Public Records of Polk County, Florida**

**CITY OF BARTOW, a Florida municipal corporation,  
Petitioner**

**v.**

**Warren Washington,  
Respondent(s).**

**AFFIDAVIT OF SERVICE**

I, **Delaila S Tait**, Code Enforcement Investigator, state as follows:

1. On 03/27/2020, I sent a copy of:

- Notice of Violation
- Notice of Hearing
- Notice of Hearing: Certification of Fines
- Notice and Order of Demolition
- Order Finding Violation
- Order Imposing Fine

- Affidavit of:  Non-Compliance  Compliance
- Order Authorizing Initiation of Demolition Process
  - Final Order Authorizing Demolition of Structure
  - Order on Request to Reduce Fine
  - Other: \_\_\_\_\_

Via  Certified Mail  First Class Mail  Other: \_\_\_\_\_

to the property owner(s) at the address mailing address listed on the Polk County Property Appraiser's website:  
**4104 Vicotria Blvd Hampton VA 23669-4242**

- 2. On 03/27/2026, I posted a copy of the same at the above-described property; and
- 3. On 03/27/2026, I posted a copy of the same at City Hall.
- 4. Alternatively, I hand delivered a copy of the same to the property owner(s) on \_\_\_\_\_ as attested to by the following signature: \_\_\_\_\_

  
\_\_\_\_\_  
Delaila Tait  
Code Compliance Investigator

STATE OF FLORIDA  
COUNTY OF POLK

I HEREBY CERTIFY that on this day, before me, by means of  physical presence or \_\_\_ online notarization, an officer duly authorized to administer oaths and take acknowledgements, personally appeared Delaila S Tait, who is personally known to me to be the person described in and who executed the foregoing instrument, and who, being sworn by me, acknowledged before me the execution of same.

WITNESS my hand and official seal in the County and State last aforesaid this 27th Day of March, 2020. Barbara C Banks Notary Public

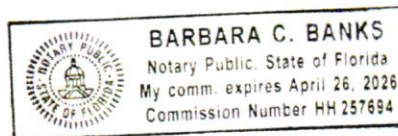

9589 0710 5270 3573 0476 91

**U.S. Postal Service™**  
**CERTIFIED MAIL® RECEIPT**  
*Domestic Mail Only*

For delivery information, visit our website at [www.usps.com](http://www.usps.com)®.

Certified Mail Fee	
\$	
Extra Services & Fees (check box, add fee as appropriate)	
<input type="checkbox"/> Return Receipt (hardcopy)	\$ _____
<input type="checkbox"/> Return Receipt (electronic)	\$ _____
<input type="checkbox"/> Certified Mail Restricted Delivery	\$ _____
<input type="checkbox"/> Adult Signature Required	\$ _____
<input type="checkbox"/> Adult Signature Restricted Delivery	\$ _____

Postmark  
Here

**Warren Washington**  
**4104 Victoria Blvd**  
**Hampton VA 23669-4242**

**IN AND FOR THE CITY OF BARTOW, FLORIDA**

**CASE NO.: 26-0111**

**IN RE: 2015 Laurel St.**

**25-30-09-000000-033090**

**N 93.59 FT OF W 66 FT OF 1 AC OFF E END OF N1/2 OF S1/2 OF NE1/4 OF NW1/4 OF NW1/4 LESS N 20 FT FOR LAUREL ST, as recorded in the Public Records of Polk County, Florida**

**CITY OF BARTOW, a Florida municipal corporation,  
Petitioner**

**v.**

**Aaron Washington,  
Respondent(s).**

**AFFIDAVIT OF SERVICE**

I, **Delaila S Tait**, Code Enforcement Investigator, state as follows:

1. On 03/27/2026 I sent a copy of:

- Notice of Violation
- Notice of Hearing
- Notice of Hearing: Certification of Fines
- Notice and Order of Demolition
- Order Finding Violation
- Order Imposing Fine

- Affidavit of:  Non-Compliance  Compliance
- Order Authorizing Initiation of Demolition Process
  - Final Order Authorizing Demolition of Structure
  - Order on Request to Reduce Fine
  - Other: \_\_\_\_\_

Via  Certified Mail  First Class Mail  Other: \_\_\_\_\_

to the property owner(s) at the address mailing address listed on the Polk County Property Appraiser's website:  
**4104 Vicotria Blvd Hampton VA 23669-4242**

- 2. On 03/27/2026, I posted a copy of the same at the above-described property; and
- 3. On 03/27/2026, I posted a copy of the same at City Hall.
- 4. Alternatively, I hand delivered a copy of the same to the property owner(s) on \_\_\_\_\_ as attested to by the following signature: \_\_\_\_\_

  
\_\_\_\_\_  
Delaila Tait  
Code Compliance Investigator

STATE OF FLORIDA  
COUNTY OF POLK

I HEREBY CERTIFY that on this day, before me, by means of  physical presence or  online notarization, an officer duly authorized to administer oaths and take acknowledgements, personally appeared Delaila S Tait, who is personally known to me to be the person described in and who executed the foregoing instrument, and who, being sworn by me, acknowledged before me the execution of same.

WITNESS my hand and official seal in the County and State last aforesaid this 27th Day of March, 2026.  
 Notary Public

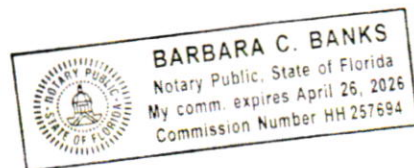

9589 0710 5270 3573 0476 84

**U.S. Postal Service™**  
**CERTIFIED MAIL® RECEIPT**  
*Domestic Mail Only*

For delivery information, visit our website at [www.usps.com](http://www.usps.com)™.

Certified Mail Fee	
\$	
Extra Services & Fees (check box, add fee as appropriate)	
<input type="checkbox"/> Return Receipt (hardcopy)	\$ _____
<input type="checkbox"/> Return Receipt (electronic)	\$ _____
<input type="checkbox"/> Certified Mail Restricted Delivery	\$ _____
<input type="checkbox"/> Adult Signature Required	\$ _____
<input type="checkbox"/> Adult Signature Restricted Delivery	\$ _____

Postmark  
Here

Aaron Washington  
4104 Victoria Blvd  
Hampton VA 23669-4242

IN AND FOR THE CITY OF BARTOW, FLORIDA

CITY OF BARTOW, FLORIDA,  
a Florida Municipal Corporation,

CASE NUMBER 26-0111

Petitioner,

vs.

RADFORD FRANCES,

Respondent(s).

\_\_\_\_\_ /

NOTICE OF HEARING

To: RADFORD FRANCES

Respondent

4104 VICTORIA BLVD HAMPTON VA 23669-4242

Reference: Real property located at LAUREL 2015 ST, Folio # 253009000000033090

**YOU ARE HEREBY NOTIFIED** that on **April 28, 2026** at 9:00 A.M., in the City Commission Chambers, City Hall, located at 450 N. Wilson Avenue, Bartow, Florida, a public hearing will be conducted by the Special Magistrate in accordance with Florida Statute 162.07 to determine whether you have violated one or more provisions and/or sections of the Code of Ordinances of the City of Bartow, specifically:

**Code Book: 2021 International Property Maintenance Code - Code Title: Section 304.7: Sub-Section: IPMC2021P2\_Ch03\_Sec304.7 Roofs and drainage. - Code Section: 304.7 Ordinance: The roof and flashing shall be sound, tight and not have defects that admit rain. Roof drainage shall be adequate to prevent dampness or deterioration in the walls or interior portion of the structure. Roof drains, gutters and downspouts shall be maintained in good repair and free from obstructions. Roof water shall not be discharged in a manner that creates a public nuisance. Conditions Found and Corrective Action Required: Structures roof is heavily damaged. Repairs must be made to code. Continued violation will result in fees/fines.**

You are entitled to be represented by counsel, present testimony and evidence and testify on your behalf. Subpoenas for records, surveys, plats and other materials and for witnesses may be requested and will be issued by the Special Magistrate upon proper request to the Recording Secretary of the Special Magistrate within five business days at (863) 534-0100 ext. 1254.

You are requested to appear before the Special Magistrate at that time to answer and defend allegations that you have violated the cited provisions of the Code of Ordinances of the City of Bartow noted above.

If you fail to attend, the Special Magistrate may base its findings and act solely on the presentation made by the City.

If the Special Magistrate finds that you have committed any violation(s), the Special Magistrate may order immediate compliance with the Code and provide in the order, in the event of failure to comply with the order within a period of time set forth therein, that a fine be imposed NOT TO EXCEED \$250.00 per day for a first violation and NOT TO EXCEED \$500.00 per day for a repeat violation for the period of non-compliance.

Please be advised that the case may be presented to the Special Magistrate and fines and costs may be assessed against you **EVEN IF THE VIOLATION HAS BEEN CORRECTED** prior to the scheduled hearing if (1) the violation was not corrected by the time specified by the Code Inspector, or: (2) the violation has been corrected and then recurred.

If any decision of the Special Magistrate affects you and you decide to appeal any decision made at this meeting with respect to any matter considered, you will need a record of the proceedings, and for such purposes you may need to ensure that a verbatim record of the proceedings is made, which record includes the testimony and evidence upon which the appeal is based.

**(THE ABOVE NOTICE IS REQUIRED BY STATE LAW. ANYONE DESIRING A VERBATIM TRANSCRIPT SHALL HAVE THE RESPONSIBILITY AT HIS/HER OWN COSTS TO ARRANGE FOR THE TRANSCRIPT.)**

Please be advised that the procedures of the Special Magistrate are governed by the Rules of the Special Magistrate and the Code of Ordinances of the City of Bartow. Copies of these Rules and Ordinances may be obtained at the Office of the City Clerk, City of Bartow. PLEASE GOVERN YOURSELF ACCORDINGLY.

**FAILURE TO APPEAR AT THE TIME SET CAN RESULT IN AN ORDER BEING ENTERED IN ABSENTIA AND A LIEN BEING IMPOSED AGAINST YOUR REAL AND PERSONAL PROPERTY WHICH MAY CAUSE LEVY AGAINST PERSONAL PROPERTY AND FORECLOSURE ON REAL PROPERTY.**

In accordance with the American with Disabilities Act, if you are a person with a disability who needs any accommodation to participate in this proceeding, you are entitled, at no cost to you, to the provision of certain assistance. Please contact the City Clerk's Office at 450 N. Wilson Avenue, P.O. Box 1069, Bartow, Florida 33831-1069 or phone (863) 534-0100 within 2 working days of your receipt of this Notice of Hearing; if you are hearing or voice impaired, call 1-800-955- 8771.

Dated: March 26, 2026

By:

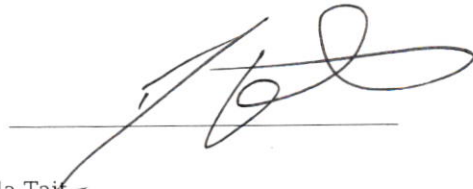

Delaila Tait  
Code Compliance Investigator  
Office of Code Compliance & Neighborhood Services  
450 N. Broadway Avenue  
Bartow, FL 33830

**CITY OF BARTOW CODE COMPLIANCE**  
**AFFIDAVIT OF COST**

**Respondents:** Frances Radford, Yvonne Washington, Marion Motley, Tamara Bostic, Timothy Bennett, Reginald Wahington, Wanda Johnson, Washington Fredrick, Sharlease Grandberry, Andrea Wahington, Ronald Washington, Warren Washington, Aaron Washington  
 4104 Victoria Blvd  
 Hampton VA 23669-4242

**Case No.:** 25-0111

**Violation Location:** 2015 Laurel St E Bartow FL 33830

**Parcel ID:** 25-30-09-000000-033090

3	SITE INSPECTION FEE @ \$25.00 EACH SITE INSPECTION	75.00
27	CERTIFIED MAIL @ \$10.48 EACH	565.92
27	REGULAR MAIL @ \$0.78 EACH	21.06
	CONTRACTOR/CITY CHARGE CLEARING VIOLATION	
2	DOCUMENT RECORDING FEE @ \$35.50	20.00
0	<b>DAYS OF FINE @</b>	<b>0</b>
	<b>TOTAL COST INVOLVED IN THIS CASE</b>	<b>681.98</b>

I, Delaila Tait, Code Compliance Investigator, certify that the itemized cost listed accurately reflects those costs incurred in the investigation of this case/respondent for City Ordinance violations.

DATE: 4/13/26

INVESTIGATOR: Delaila Tait 

STATE OF FLORIDA  
 COUNTY OF POLK

I HEREBY CERTIFY that on this day, before me, by means of  physical presence or  online notarization, an officer duly authorized to administer oaths and take acknowledgements, personally appeared Delaila Tait, who is personally known to me to be the person described in and who executed the foregoing instrument, and who, being sworn by me, acknowledged before me the execution of same.

WITNESS, my hand and official seal in the County and State last aforesaid this 13th Day of April, 2026.

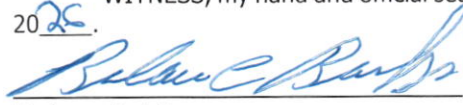
  
 Notary Public

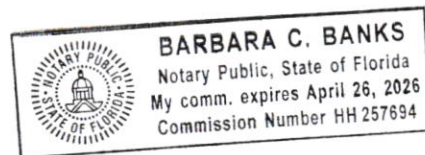

**IN AND FOR THE CITY OF BARTOW, FLORIDA**

**CASE NO.: 26-0111**

**IN RE: 2015 Laurel St E  
25-30-09-000000-033090  
N 93.59 FT OF W 66 FT OF 1 AC OFF E END OF N1/2 OF S1/2 OF NE1/4 OF NW1/4 OF  
NW1/4 LESS N 20 FT FOR LAUREL ST, PUBLIC RECORDS OF POLK COUNTY, FLORIDA.**

**CITY OF BARTOW, a Florida municipal corporation,  
Petitioner**

**v.**

**Frances Radford, Yvonne Washington, Marion Motley, Tamara Bostic, Timothy Bennett, Reginald Wahington, Wanda Johnson, Washington Fredrick, Sharlease Grandberry, Andrea Wahington, Ronald Washington, Warren Washington, Aaron Washington, Respondent(s).**

**ORDER FINDING VIOLATION**

**FINDINGS OF FACT, CONCLUSIONS OF LAW AND ORDER**

THIS CAUSE came for public hearing before the Special Magistrate on April 28th, 2026 after due notice to Respondent(s), and the Special Magistrate, having heard testimony under oath, received evidence and heard argument, issues this *Findings of Fact, Conclusions of Law and Order* pursuant to §§ 162.07(4) and 162.08(5), Fla. Stat.:

**FINDINGS OF FACT**

- 1. The Respondent(s):
  - Appeared;
  - Did not appear; or
  - Was/were represented by \_\_\_\_\_.

- 2. On or about **February 18<sup>TH</sup>, 2026**, there existed at or on the above described real property the following conditions in violation of the Code of Ordinances of the City of Bartow, such conditions constituting a nuisance and a serious threat to the public health, safety, and welfare within the meaning of § 162.06(4), Fla. Stat.:

**Violations of the Code of Ordinances of the City of Bartow:**

- (1) MPMS § 304.7 ROOFS AND DRAINAGE

(References to "MPMS" are to the *Minimum Property Maintenance Standards of the City of Bartow* as adopted by the *Bartow Property Improvement Regulations Ordinance of 2012* ("BPIRO"), § 18-16, *Code of Ord. of the City of Bartow, Fla.* References to the "FBC" are to the Florida Building Code as modified by BPIRO, §§ 18-1, 18-2, *Code of Ord. of the City of Bartow, Fla.* References to "ULDC" are to the *Unified Land Development Code of the City of Bartow, Fla.*)

- 3. Such conditions:

- continue to exist as of the date of this Order;
- were remedied prior to Hearing, having existed from the date the violation was first observed by the Code Enforcement Officer, \_\_\_\_\_, through \_\_\_\_\_, for a total of \_\_\_\_\_ days; or
- were remedied in part (Violation(s) # \_\_\_\_\_) and continue in part (Violation(s) # \_\_\_\_\_).

4. The above described real property is located and existing within the corporate limits of the City of Bartow, Florida. Respondent(s), as owner(s) of said real property is/are responsible for maintaining the same in accordance with the Code of Ordinances of the City of Bartow. All required notices pursuant to § 162.12, Fla. Stat., have been sent.

**CONCLUSIONS OF LAW**

5. This Magistrate has personal jurisdiction over the Respondent(s), and this matter is otherwise properly before this Magistrate. Further, this Magistrate has subject matter jurisdiction pursuant to the Code Enforcement Options Ordinance of 2016 of the City of Bartow, Florida.

6. The above stated facts  **do**  **do not** constitute a violation of the specific section(s) of the City Code cited in paragraph 2 herein.

**ORDER**

Based on the foregoing Findings of Fact and Conclusions of Law, and upon consideration of the gravity of the violation and any actions taken by the Respondent(s) to correct the violation, and previous violations committed by the violator, it is hereby **ORDERED** that:

- The evidence presented did not support the violation cited. The case is hereby **DISMISSED**.
- Violations did exist at the subject property but have been remedied. No fine will be imposed in this matter. However, future offenses of the same nature as cited in this case will be considered repeat offenses and subject to fines as such.
- Respondent(s) admit(s) to the violation(s) and request(s) additional time to comply. Respondent(s) has/have waived any defenses to the violation(s). Respondent(s) shall have \_\_\_\_\_ days (on or before \_\_\_\_\_) to comply or a \$\_\_\_\_\_ per day fine may be imposed.
- Respondent(s) have \_\_\_\_\_ days (on or before \_\_\_\_\_) for total compliance or a \$\_\_\_\_\_ per day fine will be imposed.
- Violation(s) number(s) \_\_\_\_\_ as identified above is/are irreparable or irreversible in nature. A one-time fine of \$\_\_\_\_\_ is imposed against the Respondent(s) in addition to any fine or costs imposed herein, if any such fine amount or costs amount is imposed.
- Pursuant to § 162.08(5), Fla. Stat., the Code Enforcement Division of the City of Bartow is hereby authorized to **SECURE** the safety condition(s) on the subject property and assess all costs incurred by it against the Respondent(s), in addition to any fine or costs imposed herein.
- The City of Bartow is hereby authorized to **ABATE** the violation(s) named herein in accordance with § 162.09(1), Fla. Stat., but shall not be required to do so. If abatement occurs, the City of Bartow may assess all costs incurred by it against the Respondent(s), in addition to any fine or costs imposed herein.

Respondent(s) shall be responsible for costs incurred by the City of Bartow in prosecuting this case totaling \$~~681.98~~. The costs shall be paid in full within 30 days of this Order (by ~~5/28/26~~, at 5:00 p.m.). If unpaid within that time, the costs will be assessed against the subject property as a lien, and this Order, or a subsequent Order Imposing Fine, may be recorded in the Public Records of Polk Count as evidence thereof.

\_\_\_\_\_  
\_\_\_\_\_  
\_\_\_\_\_

YOU ARE NOTIFIED THAT IF THIS ORDER IMPOSES A FINE, ABATEMENT COSTS, OR PROSECUTION COSTS AGAINST YOU THAT pursuant to § 162.09(3), Fla. Stat., once final, this ORDER may be recorded in the public records and thereafter may constitute a lien against the above described real property and upon any other real or personal property owned by you. FURTHER, subsequent certifications or supplemental certifications of fines may be recorded in the public records if the violations mentioned herein may be remedied by you and you fail timely to do so.

THIS ORDER is final upon rendition thereof. You may request a rehearing of an enforcement decision of the Special Magistrate by delivering a written request for rehearing to the City Clerk of the City of Bartow within ten (10) days of the date the order was mailed or served. A request for rehearing shall be based *only* on the grounds that the decision was contrary to the evidence or that the hearing involved an error on a ruling of law which was fundamental to the decision of the Special Magistrate. If no rehearing is timely requested, this Order may be recorded in the Public Records of Polk County, Florida. This Order may be appealed to Circuit Court within thirty (30) days of the date of its rendition pursuant to § 162.11, Fla. Stat., by filing a timely Notice of Appeal with the City Clerk of the City of Bartow and the Circuit Court and complying with any and all applicable court rules of procedure. All requests to challenge fines or notices of appeal must be in writing and stamped received at the Code Enforcement Division no later than 5:00 p.m. on or before the date the period expires in order to be considered timely.

**DONE AND ORDERED (RENDERED)** this \_\_\_ day of \_\_\_\_\_ at Bartow, Polk County, Florida.

ATTEST:

\_\_\_\_\_  
JACKI POOLE  
Secretary to the Special Magistrate

\_\_\_\_\_  
JOSEPH P. MAWHINNEY, ESQ.  
Special Magistrate, City of Bartow

Case No.: 26-0111  
Mailings: 4104 Victoria Blvd Hampton VA 23669-4242

**VIOLATION COURT PACKET**  
April 17, 2026

Violation Number : 26-0111	Original Complaint Number:
Parcel Number: 253009000000033090	Original Failed Inspection Number:
Owner Name: RADFORD FRANCES	Required Resolve By Date: April 28, 2026
Occupant Name:	Violation Status: Open - Violation Notice to Hearing Violation Type: Code Enforcement
Parcel Address: LAUREL 2015 ST - Unit ID:	Violation Date: March 27, 2026    Violation Time: 01:10PM
Violation Description: Structures roof is heavily damaged. 2/18/26 Violation issued	
<p><b>Code Book:</b> <u>2021 International Property Maintenance Code</u> - <b>Code Title:</b> <u>Section 304.7: Sub-Section: IPMC2021P2_Ch03_Sec304.7 Roofs and drainage.</u> - <b>Code Section:</b> <u>304.7</u></p> <p><b>Ordinance:</b> The roof and flashing shall be sound, tight and not have defects that admit rain. Roof drainage shall be adequate to prevent dampness or deterioration in the walls or interior portion of the structure. Roof drains, gutters and downspouts shall be maintained in good repair and free from obstructions. Roof water shall not be discharged in a manner that creates a public nuisance.</p> <p><b>Conditions Found and Corrective Action Required:</b> <b>Structures roof is heavily damaged. Repairs must be made to code.</b></p> <p>Continued violation will result in fees/fines.</p>	

Listing of All Actions Related to Violation Number: 26-0111  
February 18, 2026 01:05PM **Violation Created**  
Violation Created For Parcel #253009000000033090

February 18, 2026 01:13PM **Inspection #26-0129 - Scheduled**  
Inspection #26-0129 has been scheduled for this violation.

March 24, 2026 09:16AM **Inspection #26-0129 Result - Fail**  
Inspection #26-0129 was marked as failed for this violation.

March 24, 2026 09:16AM **Inspection #R26-0129-01 - Scheduled**  
Inspection #R26-0129-01 has been scheduled for this violation.

April 8, 2026 03:20PM **Owner Called/Contacted**  
Frances Radford 757-807-9464 lives out of state and is a point of contact but not THE point of contact, she was informed of a possible extension if her family who lives at the residents contacts me before the 15 of April.

---

Listing of All Tickets Issued:

---

Listing of All Images on File Relating to Case:

**Tax Parcel #:** 253009000000033090  
**Address:** LAUREL 2015 ST  
**Violation #:** 26-0111  
**Upload Date:** February 19, 2026 09:06AM



**Tax Parcel #:** 253009000000033090  
**Address:** LAUREL 2015 ST  
**Violation #:** 26-0111  
**Upload Date:** February 19, 2026 09:06AM



**Tax Parcel #:** 253009000000033090  
**Address:** LAUREL 2015 ST  
**Violation #:** 26-0111  
**Upload Date:** February 23, 2026 10:10AM



**Tax Parcel #:** 25300900000033090  
**Address:** LAUREL 2015 ST  
**Inspection #:** 26-0129  
**Inspection Date:** March 24, 2026 01:15PM  
**Upload Date:** March 24, 2026 09:15AM



**Tax Parcel #:** 25300900000033090  
**Address:** LAUREL 2015 ST  
**Inspection #:** 26-0129  
**Inspection Date:** March 24, 2026 01:15PM  
**Upload Date:** March 24, 2026 09:15AM



Baldwin C. Bush  
Signature of Person Preparing Packet

4-17-26  
Date

# Parcel Details: 25-30-09-000000-033090

## Owners [Recently purchased this property? Click here.](#)

RADFORD FRANCES	16.67%
WASHINGTON YVONNE M	16.67%
MOTLEY MARION	4.17%
BOSTIC TAMARA L	16.66%
BENNETT TIMOTHY	4.17%
WASHINGTON REGINALD	4.17%
JOHNSON WANDA B	4.16%
WASHINGTON FREDRICK	16.66%
GRANDBERRY SHARLEASE W	3.34%
WASHINGTON ANDREA	3.34%
WASHINGTON RONALD	3.33%
WASHINGTON WARREN	3.33%
WASHINGTON AARON	3.33%

## Mailing Address [\(Address Change form\)](#)

4104 VICTORIA BLVD  
HAMPTON VA 23669-4242

## Physical Street Address [Why postal city and municipality? Click here.](#)

2015 LAUREL ST E

## Postal City and Zip

BARTOW FL 33830

## Parcel Information

Municipality	<b>BARTOW (Code: 90310)</b>
	<b>430012.00</b>
Neighborhood	<a href="#">Search Recent Sales in this Neighborhood</a>
Subdivision	<b>NOT IN SUBDIVISION</b>
Property (DOR) Use Code	<b>SFR up to 2.49 AC (Code: 0100)</b>
Acreage	<b>0.12</b>
<a href="#">Community Redevelopment Area</a>	<b>City of Bartow CRA - Area III (Expansion 2011) (Code: 323)</b>

## Property Desc

**DISCLAIMER:** The property description provided is a summary of the original legal description and should not be used for conveying property, as it may render the deed invalid.

## Area Map



## Section Maps for 253009

[HTML \(opens in new tab\)](#)

[Printable PDF](#)

## Sales History

**Important Notice:** If you wish to obtain a copy of a deed for this parcel, click on the blue OR Book/Page number. If the Book/Page number does not have a blue link or if the document is restricted, it may not be available online. Please contact the Polk County Clerk

OR Book/Page	Date	Type Inst	Vacant/Improved	Grantee	Sales Price
10723/01280	12/2014	M	I	RADFORD FRANCES	\$0
4601/2262	12/2000	M	I	RADFORD FRANCES	\$100
4602/0903	12/2000	Q	I	WASHINGTON VIAN	\$100
4602/0901	12/2000	Q	I	WASHINGTON VIAN	\$100
4602/0904	11/2000	Q	I	WASHINGTON VIAN	\$100
1722/1618	03/1975	RF	E	CITY OF BARTOW	\$0

### Exemptions

**Note:** The drop down menus below provide information on the amount of exemption applied to each taxing district. The HX—first \$25,000 homestead exemption may be allocated to one or more owners. The HB second amended homestead exemption reflects the name of the first owner only.

Code	Bld. #	Description	% Ownership	Renew Cd	Year Name	Note	Value
------	--------	-------------	-------------	----------	-----------	------	-------

### Buildings

#### BUILDING 1 (SF - Single Family)

##### Building Characteristics

**Living Area:** 987 sqft  
**Total Under Roof:** 1,440 sqft  
**Actual Year Built:** 1950  
**Building Value:** \$86,832

Element	Units Information
BEDROOM	3
FULL BATH	1
HALF BATH	0
FIREPLACE	N
CNTRL HEATING / AC	N
STYLE	SINGLE FAMILY
UNITS	1 UNIT
STORY HEIGHT INFO ONLY	1 STORY FOR INFO ONLY
SUBSTRUCT	CONTINUOUS WALL
FRAME / CONST TYPE	MASONRY/BLOCK
EXTERIOR WALL	UNFINISHED
ROOF STRUCTURE	GABLE-SHINGLE

#### 2015 LAUREL ST

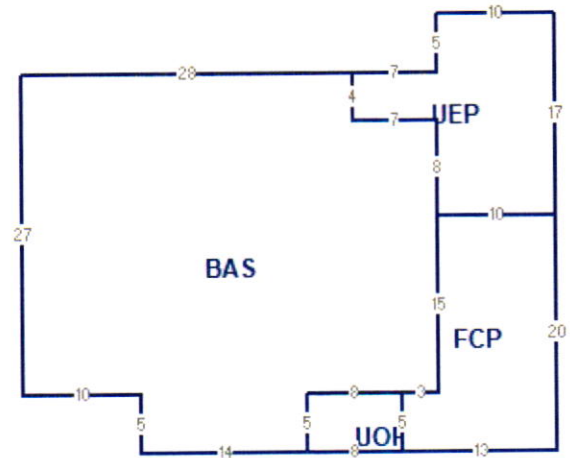

View Larger: [Double](#) - [Quadruple](#)  
 Effective Year: 1950

##### Building Subareas

Code/Description	Heated	Total
BASE AREA	Y	987
UEP UNFIN. ENCL PORCH		198
UOP UNFIN. OPEN PORCH		40
FCP FINISHED CARPORT		215
<b>Total Under Roof</b>		<b>1,440 SQ FT</b>
<b>Total Living Area</b>		<b>987 SQ FT</b>

**PERMITS**

Please contact the [appropriate permit issuing agency](#) to obtain information. This property is located in the **BARTOW** taxing district.

**Land Lines**

LN	Land Description	Ag/GreenBelt	Land Unit Type	Front	Depth	Units
1 *	RESIDENTIAL	N	SQUARE FOOT	0	0	5,083.45

\* For Zoning/Future Land Use contact Polk County or the Municipality the parcel is located in.

**NOTICE: All information ABOVE this notice is current (as of Wednesday, March 25, 2026 at 2:09:42 AM). All information BELOW this notice is from the 2025 Tax Roll, except where otherwise noted.**

**Value Summary (2025)**

Desc	Value
LAND VALUE	\$16,521
BUILDING VALUE	\$86,832
EXTRA FEATURES VALUE	\$1,000
JUST MARKET VALUE	\$104,353
AG CLASSIFIED LAND VALUE	\$0
AGRICULTURE CLASSIFICATION SAVINGS	\$0
*HOMESTEAD CAP AND SOH PORTABILITY SAVINGS	\$59,403
ASSESSED VALUE	\$44,950
EXEMPTION VALUE (COUNTY)	\$0
TAXABLE VALUE (COUNTY)	\$44,950

\*This property contains a Non Homestead Cap with a differential of \$59,403.

**Values by District (2025)**

District Description	Just Market Value	Assessed Value	Exemption	Final Tax Savings	Taxable Value	Final Tax Rate	Final Taxes
BOARD OF COUNTY COMMISSIONERS	\$104,353	\$44,950	\$0	\$0.00	\$44,950	6.634800	\$298.23
POLK COUNTY SCHOOL BOARD - STATE	\$104,353	\$104,353	\$0	\$0.00	\$104,353	3.042000	\$317.44
POLK COUNTY SCHOOL BOARD - LOCAL	\$104,353	\$104,353	\$0	\$0.00	\$104,353	2.248000	\$234.59
CITY OF BARTOW	\$104,353	\$44,950	\$0	\$0.00	\$44,950	6.108000	\$274.55
SOUTHWEST FLA WATER MGMT DIST	\$104,353	\$44,950	\$0	\$0.00	\$44,950	0.183100	\$8.23

<b>Tax Savings:</b>	<b>\$0.00</b>	<b>Total Taxes:</b>	<b>\$1,133.04</b>
---------------------	---------------	---------------------	-------------------

**Non-Ad Valorem Assessments (2025)**

LN	Code	Desc	Units	Rate	Assessment
1	FC310	BARTOW FIRE SERVICES	1.00	266.21	\$266.21
2	ST310	BARTOW STORMWATER	1.00	134.88	\$134.88
<b>Total Assessments</b>					<b>\$401.09</b>

**Taxes**

Desc	Last Year (2024)	2025 Final
Taxing District	BARTOW/SWFWMD (Code: 90310)	BARTOW/SWFWMD (Code: 90310)
Millage Rate	18.2297	18.2159
Ad Valorem Assessments	\$1,068.74	\$1,133.04
Non-Ad Valorem Assessments	\$384.48	\$401.09
<b>Total Taxes</b>	<b>\$1,453.22</b>	<b>\$1,534.13</b>

Your final tax bill may contain Non-Ad Valorem assessments which may not be reflected on this page, such as assessments for roads, drainage, garbage, fire, lighting, water, sewer, or other governmental services and facilities which may be levied by your county, city or any other special district. [Visit the Polk County Tax Collector's site for Tax Bill information related to this account.](#) Use "[Property Tax Estimator](#)" to estimate taxes for this account.

**Prior Year Final Values**

The Final Tax Roll is the 1st certification of the tax rolls by the Value Adjustment Board, [per Florida Statute 193.122\(2\), F.S.](#) This is the date all taxable property and tax rolls are certified for collection to the Tax Collector. Corrections made after this date are not reflected in the Final Tax Roll Values.

DESCRIPTION	2024	2023	2022	2021
LAND VALUE	\$11,184.00	\$10,675.00	\$6,354.00	\$4,324.00
BUILDING VALUE	\$89,822.00	\$78,106.00	\$69,032.00	\$30,992.00
EXTRA FEATURES VALUE	\$1,000.00	\$1,000.00	\$1,000.00	\$1,000.00
JUST MARKET VALUE	\$102,006.00	\$89,781.00	\$76,386.00	\$36,316.00
HOMESTEAD CAP AND SOH PORTABILITY SAVINGS	\$61,142.00	\$52,632.00	\$42,614.00	\$5,614.00
ASSESSED VALUE	\$40,864.00	\$37,149.00	\$33,772.00	\$30,702.00
EXEMPTION VALUE (COUNTY)	\$0.00	\$0.00	\$0.00	\$0.00
TAXABLE VALUE (COUNTY)	\$40,864.00	\$37,149.00	\$33,772.00	\$30,702.00

**DISCLAIMER:**

The Polk County Property Appraiser makes no representations or warranties regarding the completeness and accuracy of the data herein, its use or interpretation, the fee or beneficial/equitable title ownership or encumbrances of the property, and assumes no liability associated with its use or misuse. See the posted Site Notice.

Last Updated: Wednesday, March 25, 2026 at 2:09:42 AM